

# **3595 4B PC-to-SNET Interface**



## DECLARATION OF CONFORMITY

### The directives covered by this declaration

73/23/EEC Low Voltage Equipment Directive, amended by 93/68/EEC

89/336/EEC Electromagnetic Compatibility Directive, amended by 92/31/EEC & 93/68/EEC

### Product(s)

**3595 4B PC to S-Net Interface**

### Basis on which conformity is being declared

The product(s) identified above comply with the requirements of the EU directives by meeting the following standards:

BS EN50081-1:1992 Electromagnetic Compatibility - Generic Emission Standard  
Part 1: Residential, commercial and light industry.

BS EN50082-1:1992 Electromagnetic Compatibility - Generic Immunity Standard  
Part 1: Residential, commercial and light industry.

EN61010-1:1993 Safety requirements for electrical equipment for measurement, control and laboratory use.

Accordingly the CE mark has been applied to this product.

**Signed**

A handwritten signature in black ink, appearing to read 'Mike Hage'.

For and on behalf of Solartron, a division of Solartron Group Limited

**Authority:**

**Engineering Manager**

**Date:**

**March 1996**



## **GENERAL SAFETY PRECAUTIONS**

The equipment described in this manual has been designed in accordance with EN61010 "Safety requirements for electrical equipment for measurement, control and laboratory use", and has been supplied in a safe condition. To avoid injury to an operator or service technician the safety precautions given below, and throughout the manual, must be strictly adhered to, whenever the equipment is operated, serviced or repaired. For specific safety details, please refer to the relevant sections within the manual.

The equipment is designed solely for electronic measurement and should be used for no other purpose. Solartron accept no responsibility for accidents or damage resulting from any failure to comply with these precautions.

### **ENVIRONMENT**

This instrument must always be used within the environmental conditions (temperature, humidity, vibration, etc.), given in the Specification.

### **GROUNDING**

To minimize the hazard of electrical shock it is essential that the equipment is connected to a protective ground whenever the power supply, measurement or control circuits are connected, even if the equipment is switched off. The protective ground for ac and dc supplies is connected separately.

*AC GROUND* is connected via the ac supply cord. The cord must be plugged into an ac line outlet with a protective ground contact. When an extension lead is used, this must also contain a ground conductor. Always connect the ac supply cord to the supply outlet before connecting the control and signal cables; and, conversely, always disconnect control and signal cables before disconnecting the ac supply cord. The ac ground connection must be capable of carrying a current of 25A for a minimum of 1 minute.

### **AC SUPPLY VOLTAGE**

Never operate the equipment from a line voltage or frequency in excess of that specified. Otherwise, the insulation of internal components may break down and cause excessive leakage currents.

### **FUSES**

Before switching on the equipment check that the fuses accessible from the exterior of the equipment are of the correct rating. The rating of the ac line fuse must be in accordance with the voltage of the ac supply.

Should any fuse continually blow, do not insert a fuse of a higher rating. Switch the equipment off, clearly label it "unserviceable" and inform a service technician.

### **EXPLOSIVE ATMOSPHERES**

**NEVER OPERATE** the equipment, or any sensors connected to the equipment, in a potentially explosive atmosphere. It is **NOT** intrinsically safe and could possibly cause an explosion.

*Continued overleaf.*

## **SAFETY PRECAUTIONS** *(continued from previous page)*

### **SAFETY SYMBOLS**

For the guidance and protection of the user, the following safety symbols appear on the equipment:

<b>SYMBOL</b>	<b>MEANING</b>
	Refer to operating manual for detailed instructions of use. In particular, note the maximum voltages permissible at the input sockets, as detailed in the Specification.
	Hazardous voltages.



### **NOTES, CAUTIONS AND WARNINGS**

For the guidance and protection of the user, Notes, Cautions and Warnings appear throughout the manual. The significance of these is as follows:

**NOTES** highlight important information for the reader's special attention.  
**CAUTIONS** guide the reader in avoiding damage to the equipment.  
**WARNINGS** guide the reader in avoiding a hazard that could cause injury or death.

### **AVOID UNSAFE EQUIPMENT**

The equipment may be unsafe if any of the following statements apply:

- Equipment shows visible damage.
- Equipment has failed to perform an intended operation.
- Equipment has been subjected to prolonged storage under unfavorable conditions.
- Equipment has been subjected to severe physical stress.

*If in any doubt* as to the serviceability of the equipment, don't use it. Get it properly checked out by a qualified service technician.

### **LIVE CONDUCTORS**

When the equipment is connected to its measurement inputs or supply, the opening of covers or removal of parts could expose live conductors. The equipment must be disconnected from all power and signal sources before it is opened for any adjustment, replacement, maintenance or repair. Adjustments, maintenance or repair, must be done only by qualified personnel, who should refer to the Maintenance Manual.

### **EQUIPMENT MODIFICATION**

To avoid introducing safety hazards, never install non-standard parts in the equipment, or make any unauthorized modification. To maintain safety, always return the equipment to Solartron for service and repair.

# **3595 4B**

# **PC to S-Net Interface**

## ***USER MANUAL***

### ***PART 1***

### ***Installation and Operating Instructions***

### ***for the 3595 4B***





## *About This Manual*

The 3595 4B User Manual will help you to prepare and install the interface for operation. It will also guide you through the demonstration program, which accompanies the interface, and then explain, with an example, how to program the interface.

The relevant information on interconnecting PC and IMPs, can be found in the 3595 Series IMP Installation Guide. For this reason the information on IMP networks has been kept to a minimum.

If you're not familiar with the IMP network and the '4B interface then you are advised to read the complete manual. If the '4B has already been installed then Chapter 3 will guide you through the demonstration program.

If you are familiar with the 3595 4B and the demonstration program then Chapter 4 explains how to program the interface to your requirements.



# 3595 4B User Manual

## Part One : Contents

<b>Chapter 1</b>	<b>Introduction</b>
1	The 3595 4B Interface
2	Interface Accessories
3	Demonstration Program
4	Interface Facilities
5	3595 4B Technical Specifications
<b>Chapter 2</b>	<b>Preparing and Installing the Interface</b>
1	Introduction
2	Selecting On-Card Termination
3	Setting Up Memory Mapped Operation
4	Setting Up Port Mapped Operation
5	Using the Hardware Interrupt Option
6	Selecting the Dual Redundancy Mode
7	IMP Power Supply Options
8	Installing the Interface in the PC
9	Connecting the Interface to S-Net
10	Connecting an External Power Supply
<b>Chapter 3</b>	<b>IMPOLL: The Demonstration Program</b>
1	Introduction
2	Starting IMPOLL
3	Polling the IMPs
4	Using the IMPOLL Functions
5	Fault Diagnosis
<b>Chapter 4</b>	<b>Programming the Interface</b>
1	Introduction
2	Addressing the Interface Memory
3	Controlling IMP Communication
4	Interface Control
5	Dual Redundancy Control
6	Receiving IMP Results and Responses



# *Introduction : the 3595 4B Interface and its facilities*

## *Contents*

<b>1</b>	<b>The 3595 4B Interface .....</b>	<b>1-3</b>
1.1	PC System Requirements .....	1-3
<b>2</b>	<b>Interface Accessories .....</b>	<b>1-4</b>
<b>3</b>	<b>Demonstration Program .....</b>	<b>1-5</b>
<b>4</b>	<b>Interface Facilities .....</b>	<b>1-6</b>
4.1	IMP Commands .....	1-6
4.2	Driver Routines .....	1-6
4.3	Data Streams .....	1-6
4.4	Imp Addresses .....	1-7
4.5	Starter Software Disk .....	1-7
<b>5</b>	<b>3595 4B Technical Specifications .....</b>	<b>1-8</b>



# 1 THE 3595 4B INTERFACE

---

The 3595 4B Interface enables a PC (PC, XT and AT versions) to communicate with the Solartron S-Net system. The Interface provides full timing control and error checking, in accordance with the communication protocol. Demonstration software is provided on a 3.5" disk that accompanies the Interface.

## 1.1 PC SYSTEM REQUIREMENTS

The Interface and its accompanying software are fully compatible with PC, XT, or AT systems that have:

- A minimum of 128K user memory
- DOS version 2.1 and upwards

The Interface plugs into a standard 8-bit slot or 16-bit slot in the computer. Users of compatible systems should verify suitability with their system supplier.

Note that the 3595 4B Interface has more edge connectors than the 3595 4A. (These carry the additional interrupt signals.) Therefore, should you fit a '4B in place of a '4A on existing equipment, ensure that the extra edge connectors do not foul any components on the mainframe.

## 2 INTERFACE ACCESSORIES

---

The carton in which the 3595 4B Interface is supplied should also contain the following accessories:

- one 9-way D-type socket (352509060), to suit the external power connector.
- one 24 gage S-Net cable/10m (35950203A), with 9-way D-type plug to suit S-Net socket.
- one spare 9-way D-type plug (351309020) to suit the S-Net socket.
- two connector hoods (354006290).
- four screw locks, male (354005170).
- two S-Net terminators (35900222B) for fitting in IMPs (refer to the 3595 Series IMP Installation Guide).
- one 3.5 inch (8.9cm) disk (810000260) containing the introductory software.
- one 3595 4B User Manual (35952232).



### **3 DEMONSTRATION PROGRAM**

---

Supplied with the 3595 4B Interface is a demonstration program called IMPOLL. This allows you to send commands to the IMPs, and to receive data from them. Chapter 3 tells you how to load and run the program.

## 4 INTERFACE FACILITIES

---

### 4.1 IMP COMMANDS

The driver routines and demonstration program use commands in the form of character strings. For example, the reset command is **RE**.

A command may need to be made more specific by using it with a number. An example of this is the command **CL2**, which means: 'clear event totalise counter on channel 2'.

Several commands may be sent in a command string. Each command in the string is separated from its neighbor by a semi-colon. A simple example of a command string is **ST;CL2**. This particular command tells a digital IMP to return its status and then clear the event totalise counter on channel 2.

IMP commands and responses are dealt with in Part 2 of this manual.

### 4.2 DRIVER ROUTINES

A set of driver subroutines (3595 7E) is available for MSDOS applications from Solartron Instruments. This supports most common programming languages. Windows drivers for the 3595 Series IMPs are also available.

### 4.3 DATA STREAMS

IMPs are able to return four types of data, each type having its own format. S-Net protocol segregates these data types and returns each type on its own data stream. This allows an application program to categorize and attach different priorities to data types and thus improves the speed with which high priority data (such as event timing) is handled. The data types conveyed by each stream are as follows:

Stream 0: Scanned measurements (series of channels), or long numeric responses.

Stream 1: Single channel measurement, or short numeric responses.

Stream 2: Event information (3595 2A and 3595 2B only).

Stream 3: Command responses, in ASCII characters. Typical examples of this data type are status information or command confirmation.

## 4.4 IMP ADDRESSES

Each IMP in the system must have a unique address. An IMP is assigned its address by a pair of rotary switches inside the IMP connector block. The procedure for setting the switches is described in the 3595 Series IMP Installation Guide. The 3595 4B Interface can handle up to 50 IMPs, with addresses from 1 to 50 inclusive.

## 4.5 STARTER SOFTWARE DISK

Before attempting to use your IMPOLL demonstration program check the disk status and issue. This will ensure that you have the correct software. Then you should load the disk, verify it, and make a backup copy.

Making a backup copy of the disk is strongly recommended. The backup can then be used as the working copy, and the original stored in a safe place. Should the working copy be corrupted, then the original can be used to obtain a new one. **Note that the contents of the disk are protected by copyright.** Backup copies may only be used in conjunction with the Interface supplied by Solartron Instruments.

**Caution:** Every effort is made to ensure that the disk containing IMPOLL is virus-free. However, it is always good security practice to virus check any disk before use.

### 4.5.1 Disk Status and Issue

The disk should be labeled:

```
3595 4A IMP/PC STARTER SOFTWARE
PART NUMBER: 35955801          STATUS a          ISSUE a
DATE:          dd-mmm-yyyy      DOS 3.3
COPYRIGHT SOLARTRON INSTRUMENTS 199n
```

The disk verification and backup procedure is as follows:

1. To verify the disk, load the disk into drive A and type: CHKDSK A:

Any errors on the disk will be reported by the PC.

2. To check the files on the disk type: DIR A:

The screen will then display the files on disk. The following file should be present:

IMPOLL.EXE, a demonstration program

3. Use the DOS commands DISKCOPY or BACKUP to make a backup, as detailed in the DOS manual. **Note:** DOS is not provided on the disk: to make a 'bootable' backup use the /S option when formatting the target (backup) disk.

### Memory location and usage

Interface base address variable from hex.80000 to hex.FFE00 in steps of 512 bytes.

Memory usage of 512 bytes.

Interrupt vector may be routed to PC I/O interrupt lines IRQ2-3, IRQ5-7, IRQ10-14, or disabled.

### Connections

62-way edge connector for PC (I/O) expansion bus.

9-way D-type female connector for 'S-Net'.

9-way D-type male connector for 'ext. power'.

### Environment

Temperature:	operating	0°C to 55°C (50% RH).
		0°C to 45°C (95% RH).

	storage	-40°C to 70°C.
--	---------	----------------

### Communication (S-Net) capability

Maximum of 50 IMPs.

Maximum S-Net cable length 1500m.

### S-Net Power Supply capability

Up to 5 IMPs or Universal IMPs can be supplied, at limited distances, from an IBM PC internal supply.

Up to 50 IMPs or Universal IMPs can be supplied from an external power supply. The actual number depends on the voltage of the external supply and on the length and gauge of the S-Net cable. See the 3595 IMP Installation Guide for details.

### Power Drain (on PC)

5V, 600mW max.

12V, 50mW max. plus 1.2W max for each IMP, and 1.8W for each Universal IMP, powered from the internal supply

(up to a maximum of 5 IMPs).

**Power Drain (from external power supply, if used):**

1.2W max. per IMP.

**Requirements for external power supply, if used:**

12 to 50V DC, dependent on system size and S-Net wire gauge.

Supply ripple less than 100mV rms.

**Physical dimensions:**

Overall length, 179mm/7.05in.

Overall height, 130mm/5.12in.

Overall width, 25mm/1.0in.

Overall weight, 0.2kg/0.44lbs.



## Preparing and Installing the 3595 4B Interface

### Contents

<b>1</b>	<b>Introduction .....</b>	<b>2-3</b>
<b>2</b>	<b>Selecting On-Card Termination .....</b>	<b>2-4</b>
<b>3</b>	<b>Setting Up Memory Mapped Operation .....</b>	<b>2-5</b>
	3.1 Assigning A Memory Location For Solartron Software .....	2-5
	3.2 Assigning A User Defined Memory Location .....	2-7
<b>4</b>	<b>Setting Up Port Mapped Operation .....</b>	<b>2-8</b>
<b>5</b>	<b>Using The Hardware Interrupt Option .....</b>	<b>2-9</b>
<b>6</b>	<b>Selecting The Dual Redundancy Mode .....</b>	<b>2-9</b>
<b>7</b>	<b>Imp Power Supply Options .....</b>	<b>2-10</b>
<b>8</b>	<b>Installing The Interface In The PC .....</b>	<b>2-10</b>
<b>9</b>	<b>Connecting The Interface To S-Net .....</b>	<b>2-13</b>
	9.1 S-Net Cables .....	2-14
	9.2 Cable Selection .....	2-14
	9.3 Cable Selection For Imps Using Internal Supply .....	2-15
	9.4 Cable Selection For Imps Using External Supply .....	2-15
<b>10</b>	<b>Connecting An External Power Supply .....</b>	<b>2-18</b>
	10.1 External Power Supply Requirements .....	2-19

## List of Figures

Figure 2.1	S-Net cable terminations .....	2-4
Figure 2.2	Location of S-Net termination Jumper J202 on Interface pcb.....	2-4
Figure 2.3	Location of computer memory switchbank on 3595 4B pcb. ....	2-5
Figure 2.4	Setup for a PC with monochrome CGA or VGA graphics. ....	2-5
Figure 2.5	Setup for 3595 4B in a PC with an EGA adapter and Solartron Software. ....	2-6
Figure 2.6	Setup for 3595 4B in a PC computer with extended memory. ....	2-6
Figure 2.7	Port mapped mode: switch setup example 1 .....	2-8
Figure 2.8	Port mapped mode: switch setup example. ....	2-8
Figure 2.9	Interrupt select links.....	2-9
Figure 2.10	Selecting the dual redundancy mode .....	2-9
Figure 2.11	Location of the external supply jumper J201 .....	2-10
Figure 2.12	Removal of expansion slot cover. ....	2-11
Figure 2.13	Fitting the interface card retaining screw. ....	2-12
Figure 2.14	Location of the S-Net connector on the PC rear panel. ....	2-13
Figure 2.15	Minimum S-Net cable gage for 24V (1A maximum) external supply .....	2-16
Figure 2.16	Minimum S-Net cable gage for 50V (1A maximum) external supply .....	2-17
Figure 2.17	Location of the 'ext power' connector on the PC rear panel. ....	2-18

## List of Tables

Table 2.1	Simplified Memory Map of the PC. ....	2-7
Table 2.2	S-Net Connections.....	2-13
Table 2.3	Cables Recommended for S-Net .....	2-14
Table 2.4	Max. cable lengths for IMPs using the interface internal supply. ....	2-15
Table 2.5	Ext. Power Connector .....	2-18



# 1 INTRODUCTION

---

This chapter tells you how to set up and install the 3595 4B Interface. The information given relates to card issue A and subsequent issues (June '95 onwards).

The steps to follow are:

1. Select the on-card S-Net termination. (Section 2)
2. Set up the Interface for *memory mapped* operation (Section 3) or *port mapped* operation (Section 4). **Note that** memory mapped operation should be used for the IMPOLL demonstration program.
3. If required, set up the hardware interrupt option. (Section 5)
4. Decide on IMP power supply option. Your decision may affect the S-Net cable required and may also make it necessary for you to remove a link on the Interface. (Section 6)
5. Install the Interface in the PC. (Section 7)
6. Connect the Interface to S-Net. (Section 8)
7. Where required, connect the interface to an external power supply. (Section 9)

## PRECAUTIONS

### Static Electricity

The Interface uses MOS (metal-oxide semiconductor) integrated circuits, which can be damaged by static electricity. Keep the card in its conductive plastic packaging until it is needed for fitting. Do not touch the card edge connectors. Avoid handling the card, except by its free edges.

### High Voltages

Before opening the cabinet of the PC, switch the power off and disconnect the supply lead from the mains power supply. Do not operate the PC with the cover removed.

## 2 SELECTING ON-CARD TERMINATION

To avoid signal reflections the S-Net cable must be correctly terminated at each end. The way in which this is done depends on how the cable is connected between Host PC and IMPs. The two basic arrangements are shown in Figure 2.1.

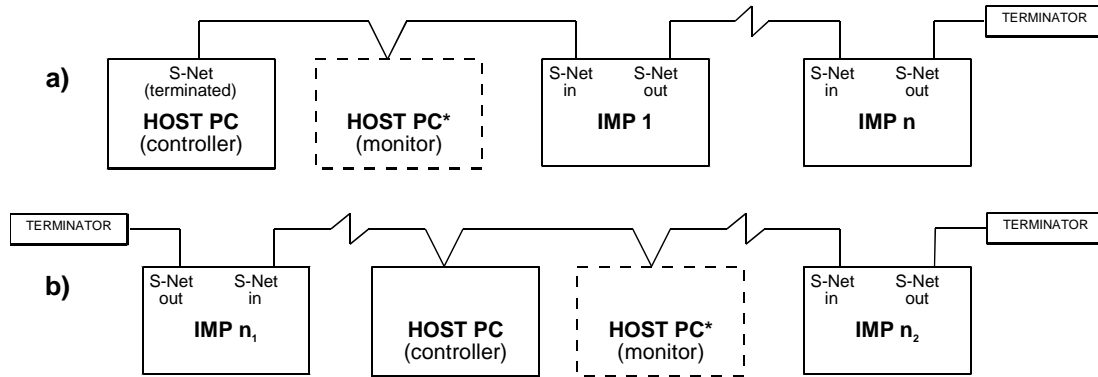

\*For Dual Redundancy systems.

**Figure 2.1 S-Net cable terminations**

Where the PC is located at the end of S-Net (Figure 2.1a) then the S-Net cable is terminated on the 3595 4B Interface card. Here, connection between cable and terminator is made through Jumper 202 (Figure 2.2). The other terminator is fitted to the S-Net terminals of the IMP at the opposite end of the cable.

Where the PC is located between IMPs (Figure 2.1b) the on-card termination must be disconnected. To do this, carefully remove Jumper J202. A cable terminator is then fitted to an IMP at both ends of the S-Net cable.

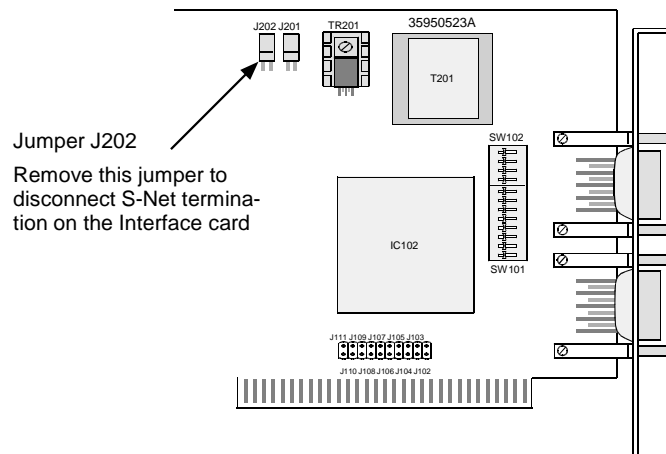

**Figure 2.2 Location of S-Net termination Jumper J202 on Interface pcb**

Two S-Net cable terminators for fitting to the IMPs are supplied with the 3595 4B Interface. Instructions on how to fit S-Net cables and cable terminators to the IMPs are given in the 3595 IMP Installation Guide.

### 3 SETTING UP MEMORY MAPPED OPERATION

#### 3.1 ASSIGNING A MEMORY LOCATION FOR SOLARTRON SOFTWARE

The switch settings vary for different PCs.

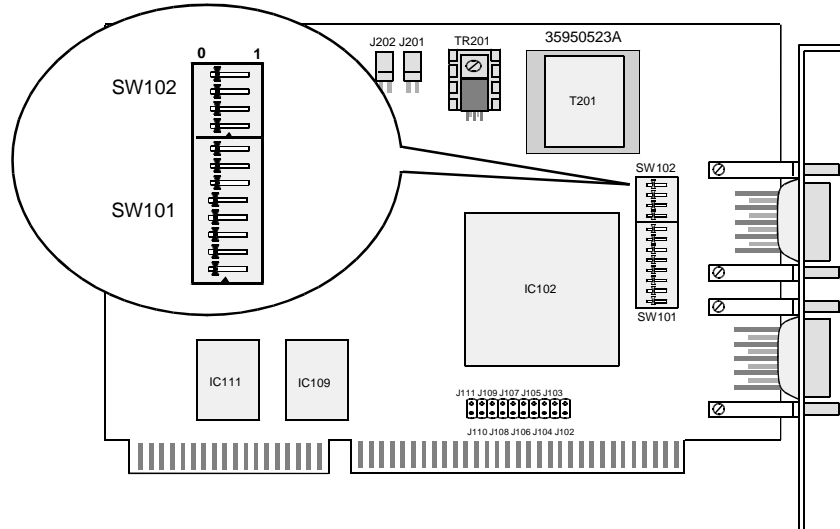
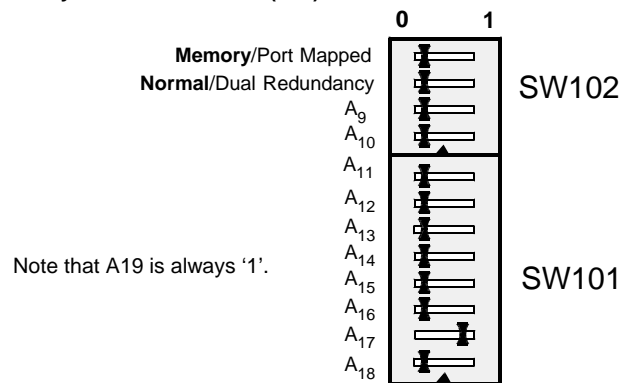

**Figure 2.3** Location of computer memory switchbank on 3595 4B pcb.

If the Interface is to be installed into a PC with a monochrome CGA or VGA graphics adapter, and Solartron software is to be used, set the on-card switch banks to address A 00 00 hex as shown in Figure 2.4.

**Note:** If the PC is fitted with an Enhanced Graphic Adapter (EGA) the address switch setting for A 00 00 hex *cannot* be used.

Example memory address is A 00 00 (hex)



**Figure 2.4** Setup for a PC with monochrome CGA or VGA graphics.

If the Interface is to be installed in a PC with an EGA adapter, and Solartron Instruments software is to be used, set the on-card switch banks to address D 00 00 hex as shown in Figure 2.5.

Example memory address is D 00 00 (hex)

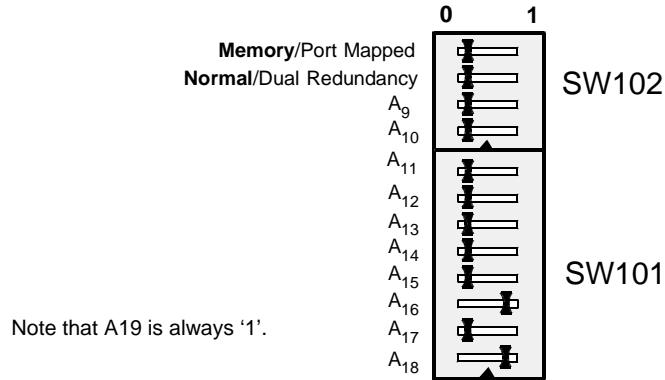

Figure 2.5 Setup for 3595 4B in a PC with an EGA adapter and Solartron Software.

If the Interface is to be installed in a PC computer that has Expanded or Extended memory, set the on-card switch banks to address C A0 00 hex as shown in Figure 2.6.

Example memory address is C A0 00 (hex)

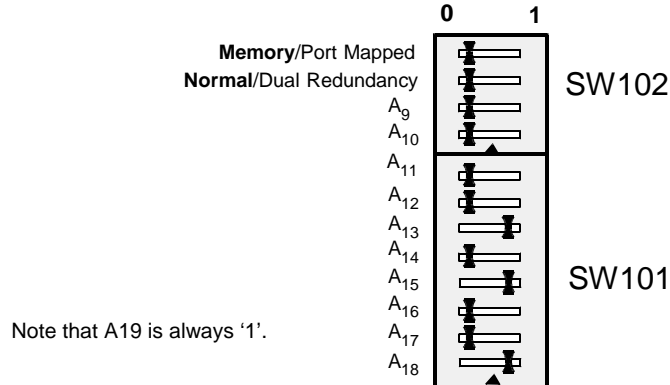

Figure 2.6 Setup for 3595 4B in a PC computer with extended memory.

### 3.2 ASSIGNING A USER DEFINED MEMORY LOCATION

A simplified map of the PC memory is shown in Table 2.1. The Interface occupies 512 bytes, of which the lowest address is known as the base address. This address can be set in the range 8 00 00 (hex) to F FE 00 (hex).

**Table 2.1 Simplified Memory Map of the PC.**

Base Address		Function
Dec.	Hex.	
0 624K	00 00 00 ↓ 9 C0 00	Read/write Memory and Memory Expansion
640k    752K	A 00 00 A 02 00 ↓ A C0 00 B 00 00 B 40 00 B 80 00 B C0 00	IMP/PC Interface, if fitted to PC with CGA or VGA.  Monochrome control.  Color/graphics control.
768k    944K	C 00 00 ↓ C A0 00 ↓ D 00 00 D 02 00 ↓ E C0 00	IMP/PC Interface, if PC has extended/ expansion memory.  IMP/PC Interface, if fitted to PC with EGA.
960K 1008K	F 00 00 ↓ F C0 00	68K Base system, ROM, BIOS and BASIC.

↑  
 Reserved for  
 Monitor Control  
 ↓  
 ↑  
 192K reserved for  
 expansion/control  
 ↓

The base address used for Solartron software is A 00 00 (hex), C A0 00 (hex), or D 00 00 (hex). This places the Interface in a normally unused area of memory reserved for monitor control or expansion and control.

**Note:** To avoid conflict with other interface cards the address of the 3595 4B Interface may be set to D 00 00.

## 4 SETTING UP PORT MAPPED OPERATION

As an alternative to memory mapped addressing, the 3595 4B Interface can be operated in port mapped mode. All you do is set the **Memory/Port Mapped** toggle on switch SW102 to '1' and set up a port address for the Interface on toggles **A4** through **A9** on switch SW101. See the examples in Figures 2.7 and 2.8 below.

If you intend to use port mapped addressing for the Interface then you should ensure:

- that your PC software is compatible with this mode and
- that the port address you select for the Interface is unique.

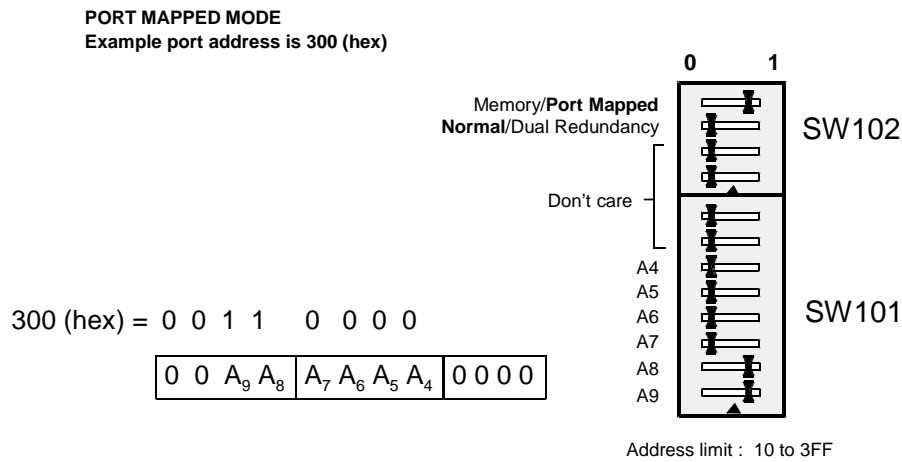

**Figure 2.7** Port mapped mode: switch setup example 1

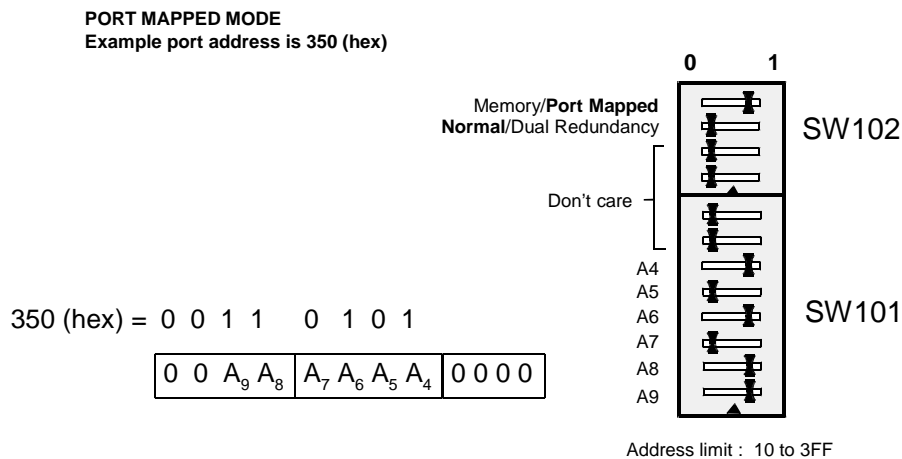
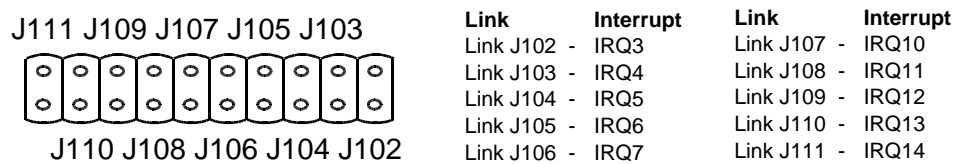

**Figure 2.8** Port mapped mode: switch setup example.

## 5 USING THE HARDWARE INTERRUPT OPTION

Ten hardware interrupt lines are available on the PC's expansion bus. These can be used in application and driver programs. However, writing these programs requires an in-depth knowledge of both PC interrupt programming and dual-port memory control of the S-Net interface application layer.

Link bank J102-J111 (Figure 2.9) selects which one of the PC's interrupt lines is to be connected to the Interface interrupt line. No more than one line should be selected, and all links should be 'open' if Solartron driver routines are to be used.



**Figure 2.9** Interrupt select links (SW103)

When transmit and receive interrupts are enabled on the Interface memory control page the Interface interrupt output is set 'high'. This occurs when the network is ready for a transmission sequence to, or a data sequence from, an IMP.

## 6 SELECTING THE DUAL REDUNDANCY MODE

The 3595 4B Interface can be set for operation in a 'dual redundancy' mode. To do this you set the **Normal/Dual Redundancy** toggle on switch SW102 to '1'. See Figure 2.10.

In a dual redundancy system two 3595 4B Interfaces are used. One is used by the designated controller and the other by the designated monitor (the control backup). The **Normal/Dual Redundancy** toggle must be set to '1' in each case.

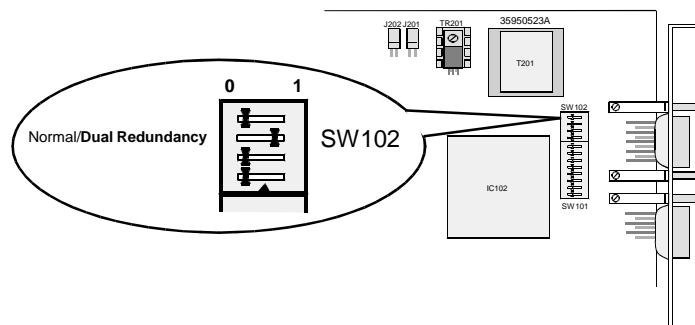

**Figure 2.10** Selecting the dual redundancy mode

Details of the Interface register through which dual redundancy is controlled are given in Chapter 4.

## 7 IMP POWER SUPPLY OPTIONS

IMPs may be supplied with power from any one of three sources:

- From the internal power supply of the 3595 4B interface, via the S-Net cable. This supply can provide 12V for the S-Net system.
- From an external 12V-50V dc power supply connected to the external power plug on the Interface; again, via the S-Net cable. The location and the pin numbering of this external power plug are detailed in Section 9. This supply allows up to 50 IMPs to be operated with a maximum S-Net cable length of 1 km.

The IMP power supply is automatically switched to the external source when a voltage over 12V is applied to the external power plug on the Interface. Where the external power source is used continuously it is recommended that connector J201 on the Interface card is removed. See Figure 2.11.

- Directly from a power supply that is local to the IMP(s). For further information on this refer to the 3595 Series IMP Installation Guide.

Each IMP consumes approximately 1W (1.2W at power-up). The 3595 1D Analog Output IMPs can, in some applications, require more. In this case special consideration is needed. Refer to the 3595 Series IMP Installation Guide for details.

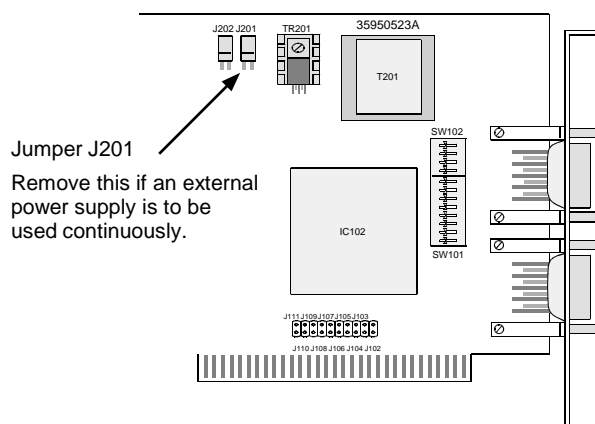

**Figure 2.11** Location of the external supply jumper J201

### 7.1 SUPPLY CONSIDERATIONS FOR THE VIMP

A VIMP is powered from two sources: S-Net conveys power to the communications module, whilst a 3595 95D Power Supply, local to the VIMP, supplies the vibration measurement front end.

Depending on the total power required from S-Net, source a. or source b. (as described above) can be used to provide the power for the VIMP communications module.



The procedure for installing the 3595 4B Interface in the PC is as follows:

1. Set all power switches to 'off'.
2. Unplug all cables from the mains power supply.
3. Disconnect all cabling from the rear of the PC.
4. Remove the PC casing. If you require help in doing this, refer to the PC manual.
5. Remove the screw securing the cover of the expansion slot in which the Interface card is to be installed and slide the expansion slot cover out of the PC frame, (Figure 2.12) Save this screw for securing the Interface.

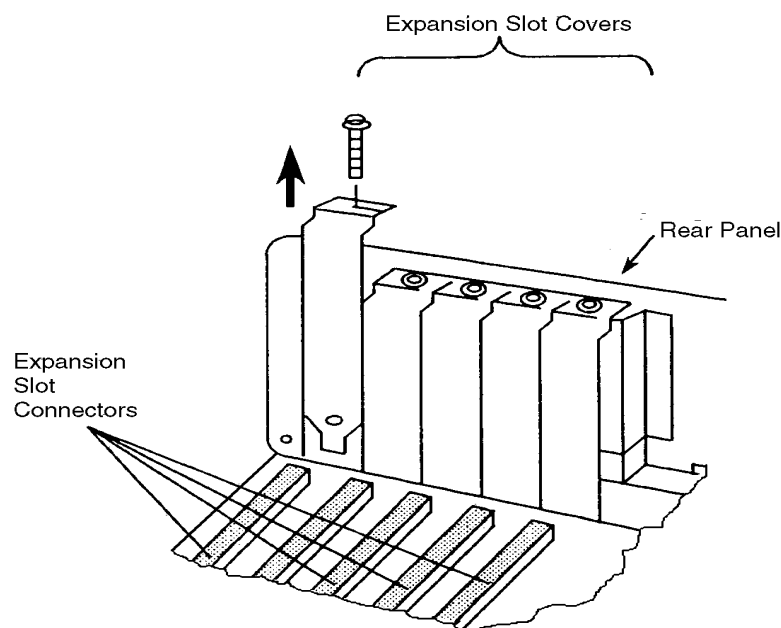

**Figure 2.12** Removal of expansion slot cover.

6. Remove the Interface card from its protective cover and check that it is prepared as described in Sections 2 through 6 in this chapter.
7. Holding the card by its corners, press it firmly into the expansion slot prepared in step 5. Align the 'U' shaped slot in the card retaining bracket with the hole in the rear panel of the PC (Figure 2.13). Fit the securing screw, which should be snug against the inside of the 'U'. Tighten the screw.

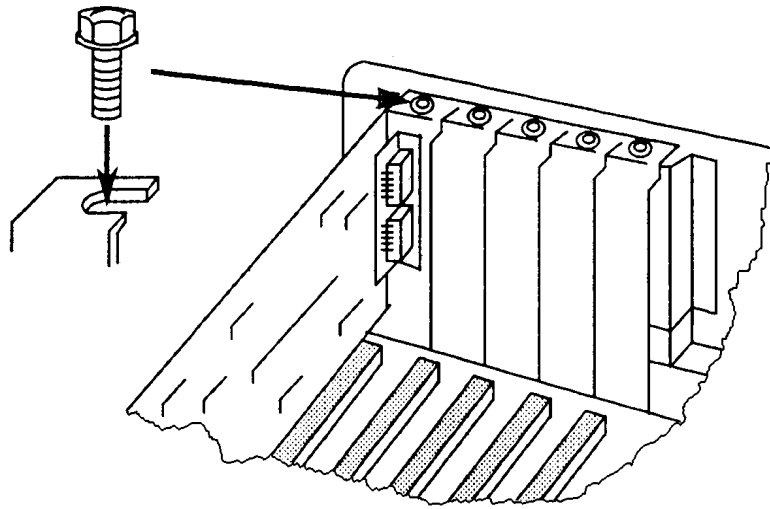

**Figure 2.13 Fitting the interface card retaining screw.**

8. Refit the PC cover and retaining screws, as described in the PC manual.
9. Refit all system cabling.
10. Complete the installation by connecting the S-Net cable and external power supply (as required), as described in Sections 8 and 9.

The S-Net cable is connected to the PC through a D-type connector on the Interface card. The location of this connector (with the interface card fitted to the PC) is shown in Figure 2.14. The pin functions of the S-Net connector are listed in Table 2.2.

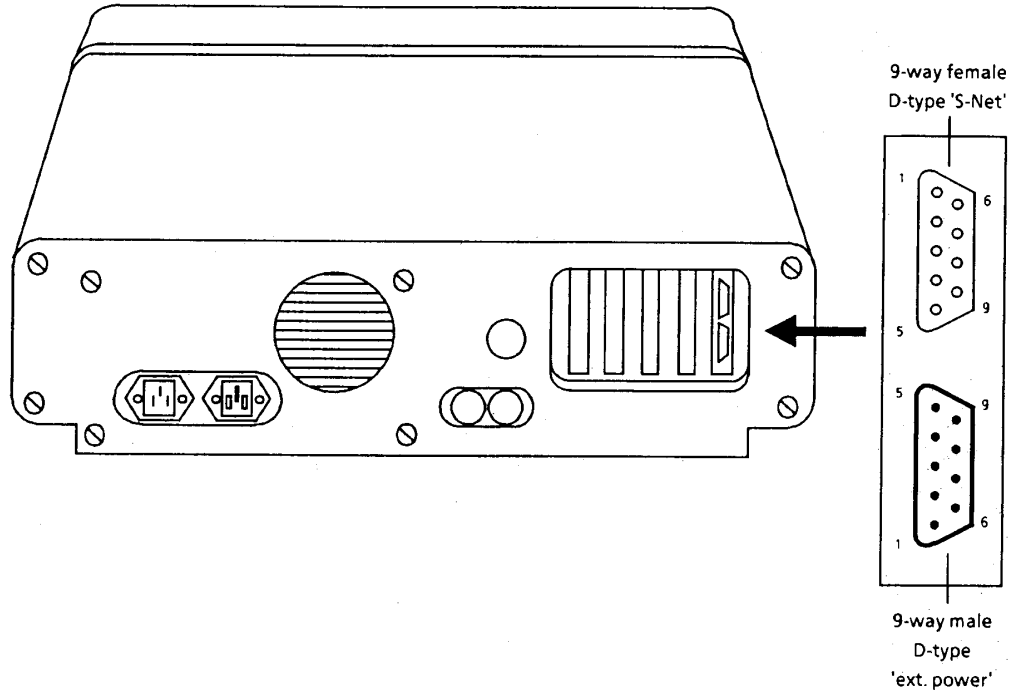

**Figure 2.14** Location of the S-Net connector on the PC rear panel.

**Table 2.2** S-Net Connections.

Pin	Function
1,2,6	SHIELD
7,8,9	- S-Net line
3,4,5	+ve S-Net line

In applications where signals and IMP power are both delivered via the S-Net it is important that the core of the S-Net cable is of an adequate gage. See Sections 8.1 and 8.2 for details.

## 9.1 S-NET CABLES

IMPs are linked to the 3595 4B Interface by S-Net, a serial communications network. The S-Net cable consists of a twisted pair of multi-stranded wires with a screen around them and has a nominal characteristic impedance of 100Ω. Unscreened cables may be used, but in electrically hostile environments S-Net signals may be subject to interference. In most applications signals and IMP power are both delivered via the S-Net cable, which is connected to a D-type connector on the Interface.

Table 2.3 lists the cables selected by Solartron as being particularly suitable for linking IMPs to the Interface. The cables are intended for general-purpose use.

**Table 2.3 Cables Recommended for S-Net**

Cable Gage	Brand Names	Part No.
12 AWG	Brand-Rex T12459	480120940
16 AWG	Brand-Rex T12460, Alpha 9820, Belden 9860	480120910
18 AWG	Brand-Rex CD8920251, Belden 9250	480121040
20 AWG	Brand-Rex BC 57207, Alpha 9818, Belden 9207, Belden 9815 (direct burial)	480120920
24 AWG	Brand-Rex BI56641, Alpha 2400, Belden 8641	480120700

Approximately 10 metres of 24 AWG Belden 8641 cable are provided with each module. This is sufficient for small data acquisition systems or for testing purposes. The connections are: S-Net +ve=black and S-Net -ve=white.

## 9.2 CABLE SELECTION

Cable selection depends on two cable characteristics:

1. The a.c. attenuation of the cable. This affects the digital communications running back and forth along the cable, between the IMPs and the interface. There are two specific points to consider:
  - a. The high a.c. attenuation of the 24 AWG cable means that S-Net using this cable cannot be longer than 660 meters.
  - b. The low a.c. attenuation of the 14 and 18 AWG cables means that S-Nets using these cables can extend up to 1.5km. The large diameter of these cables necessitates special consideration when making connections to the IMP. For details see the 3595 Series IMP Installation Guide or consult Solartron Instruments.
2. The d.c. resistance of the cable. This, and the voltage of the power supply, determines the maximum number of IMPs that can be powered via the cable. Generally, if any IMPs on the network are powered from the interface via the S-Net cable, it is important that a cable of adequate gage is used. The optimum cable size depends on the number of IMPs to be powered via the S-Net cable, the cable length required and the power supply voltage. Guidance on choosing the cable, either for power provided internally from the interface or from an external supply via the interface, is given in Sections 9.2.1 and 9.2.2.

### 9.3 Cable Selection For Imps Using Internal Supply

The internal power supply of the interface can supply 12V to the S-Net system. For this, Table 2.4 shows the recommended maximum cable length, in meters, for a given gage of cable and number of IMPs.

Note that Table 2.4 is based on an IBM PC with only the 3595 4B Interface card fitted. Therefore the figures given may be different for another make of PC. If additional cards using the 12V rail are fitted then the maximum cable length will decrease correspondingly.

**Table 2.4 Max. cable lengths for IMPs using the interface internal supply.**

No. of IMPs	Maximum Cable Length (Meters)				
	12 AWG (3,4mm <sup>2</sup> )	16 AWG (1.3mm <sup>2</sup> )	18 AWG (0.8mm <sup>2</sup> )	20 AWG (0.5mm <sup>2</sup> )	24 AWG (0.2mm <sup>2</sup> )
1	725	410	225	135	50
2	345	160	100	60	20
3	230	105	65	40	10
4	175	80	50	30	10
5	140	60	40	25	10

### 9.4 Cable Selection For Imps Using External Supply

When IMPs are powered from an external supply connected to the interface it is possible to use longer lengths of S-Net cable than those listed in Table 2.4. It is important, however, that the core of the cable is of an adequate gage. The actual gage required depends on the number of IMPs to be powered, their distribution along the cable and the power supply voltage.

To select a suitable wire gage and supply voltage for a given system, refer to the cable selection graphs (Figures 2.15 and 2.16). These graphs assume the worst case distribution of IMPs, i.e. all IMPs grouped at the far end of the cable, and incorporate a safety factor.

As an example of using the cable selection graphs, assume that the supply voltage has been fixed at 24V and that ten IMPs are to be powered via the S-Net cable. The total cable length is expected to be around 300 meters. For a 24V supply, refer to Figure 2.15 and determine the point on the graph where '10 IMPs' and '0.3km' intersect; in this case, the 16 AWG region. This is the smallest gage cable that can be used. Therefore, 16, 14 or 12 AWG cables are suitable.

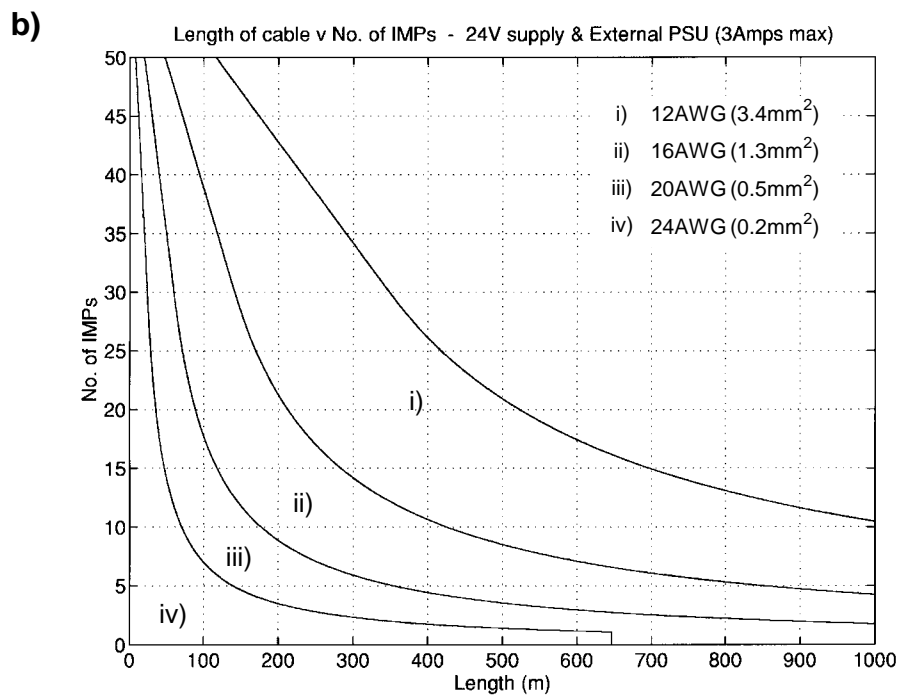
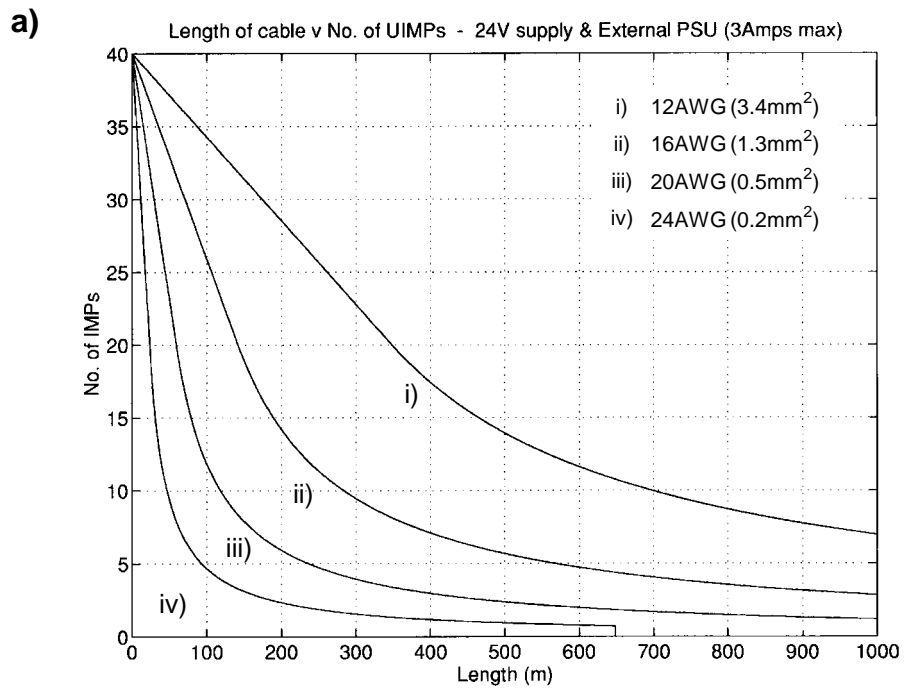

**Figure 2.15 Minimum recommended wire gage for a 24V external supply for:**  
**a) Universal IMPs and b) other IMPs.**

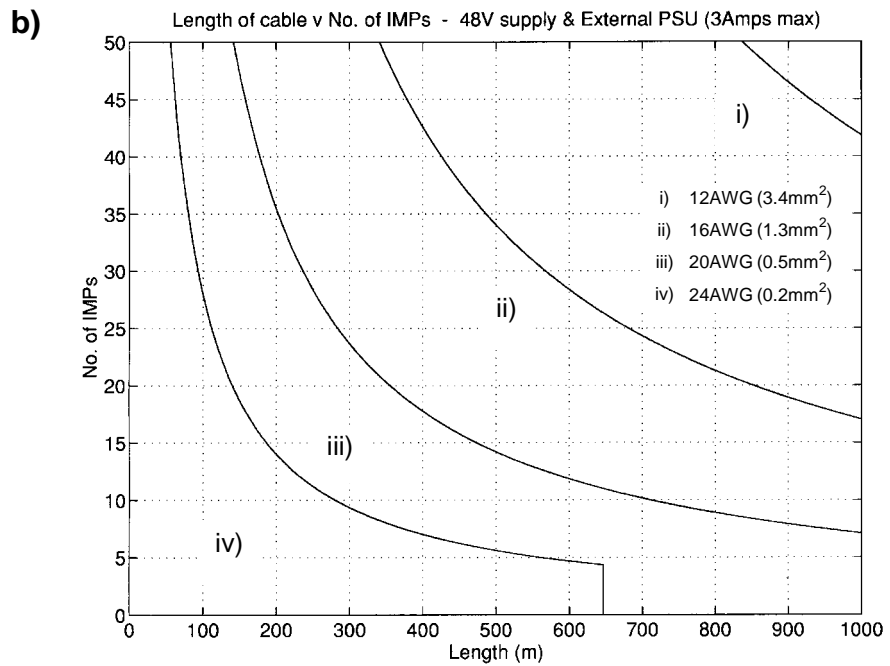
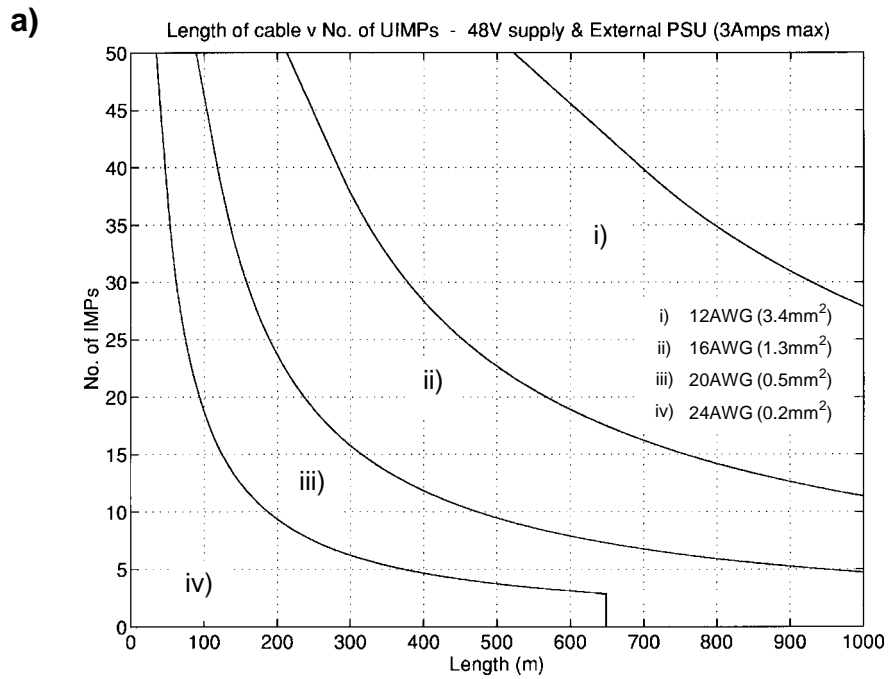
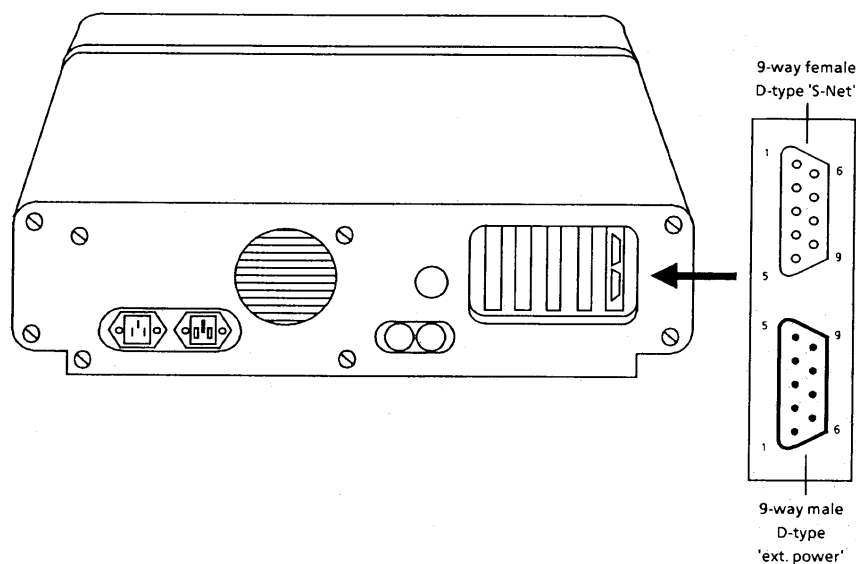

**Figure 2.16** Minimum recommended wire gage for a 48V external supply for:  
**a) Universal IMPs and b) other IMPs.**

IMPs can be powered from an external power supply connected to the 3595 4B Interface. This supplies power to the IMPs through S-Net in exactly the same way as the internal power supply, but the extra capacity provided by the external supply allows up to 50 IMPs to be operated with a maximum cable length of 1km.

With Jumper J201 fitted the Interface switches from the internal to the external supply when the voltage of the external supply exceeds 12V. Should you wish to power the IMPs continuously from the external supply then Jumper J201 should be removed. (See Section 6.)

The external power supply connection to the PC is made through a D-type connector on the Interface card. The location of this connector (with the interface card fitted to the PC) is shown in Figure 2.17. The connector pin functions are listed in Table 2.5.



**Figure 2.17** Location of the 'ext power' connector on the PC rear panel.

**Table 2.5** Ext. Power Connector

Pin	Function
6,7,8,9	+ve 12-50V, 1A max.
1,2,3,4,5	-ve



## 10.1 EXTERNAL POWER SUPPLY REQUIREMENTS

An external power source must fulfill the following requirements:

- Current limited to 1.5A to 5A, or protected by a 5A fuse.
- Voltage 12V to 50V. This depends on the wire gage, the cable length and the number of IMPs connected to the cable.
- Supply ripple less than 100mV rms.

It is permissible for a battery-powered S-Net system to have a charger permanently connected. Batteries generally provide sufficient output smoothing. A battery powered system must be protected by a fuse (~5A).

A suitable supply, the 3595 95A 48V System PSU, is available from Solartron Instruments.



# IMPOLL: The Demonstration Program

## Contents

<b>1</b>	<b>Introduction</b> .....	3-3
<b>2</b>	<b>Starting Impoll</b> .....	3-3
<b>3</b>	<b>Polling The Imps</b> .....	3-4
<b>4</b>	<b>Using The Impoll Functions</b> .....	3-5
4.1	Sending Imp Commands (Function F1) .....	3-5
4.2	Receiving Imp Data (Function F2) .....	3-7
4.3	Clearing 'Err' (Error) Indications (Function F3) .....	3-11
4.4	Adjusting The Display Colors (Function F9) .....	3-11
4.5	Exiting Impoll (Function F10) .....	3-11
<b>5</b>	<b>Fault Diagnosis</b> .....	3-12

### List of Figures

<i>Figure 3.1</i>	<i>The preliminary IMPOLL screen.</i> .....	3-3
<i>Figure 3.2</i>	<i>The Receive Poll Table</i> .....	3-4
<i>Figure 3.3</i>	<i>The Receive Scan Table</i> .....	3-8
<i>Figure 3.4</i>	<i>The Receive Event Table</i> .....	3-10

### List of Tables

<i>Table 3.1</i>	<i>Receive Poll Responses</i> .....	3-4
------------------	-------------------------------------	-----

<i>Table 3.2</i>	<i>Typical IMP Command Strings</i> .....	3-6
<i>Table 3.3</i>	<i>Streamed Data Types</i> .....	3-7
<i>Table 3.4</i>	<i>Fault Diagnosis and Elimination</i> .....	3-13

## 3-2 IMPOLL: The Demonstration Program

# 1 INTRODUCTION

---

The demonstration program, IMPOLL, allows you to send IMP commands with the function keys on your computer keyboard and to read back the IMP responses on a VDU. You can use IMPOLL either to familiarize yourself with the operation of an S-Net system or as a diagnostic aid.

# 2 STARTING IMPOLL

---

Start IMPOLL by typing in the DOS command: IMPOLL. The preliminary screen (Figure 3.1) is then displayed and IMPOLL begins by checking the following standard Interface addresses :- A000, D000, CA00 and DFE0. The first Interface to respond correctly is used by IMPOLL. A message, 'Checking for Interface Card at *nnnn*' tells you the address of the Interface presently being checked out.

Should you wish IMPOLL to use a specific Interface, append the Interface address to the IMPOLL command. For example, the command IMPOLL CA00 tells IMPOLL to check out only the Interface at address CA00.

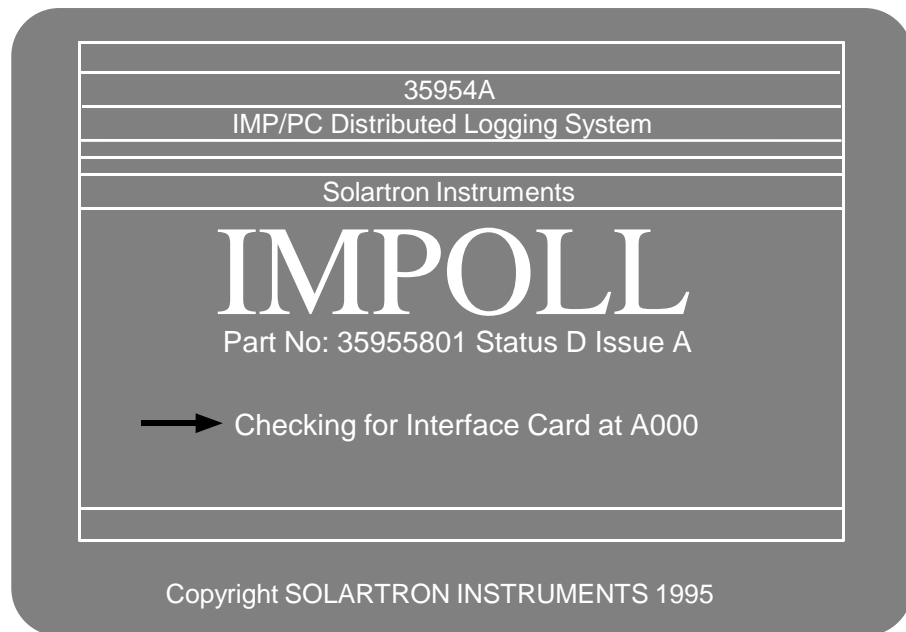

**Figure 3.1** The preliminary IMPOLL screen.

If no Interface is found IMPOLL terminates showing the DOS prompt. In this case you should check that an Interface is fitted and that the on-card switches are set up correctly, as shown in Chapter 2.

### 3 POLLING THE IMPs

After IMPOLL has found the interface, it resets all IMPs, checks which IMP addresses are used, and determines which type of IMP is connected at each address. (If no IMPs are found, the message ‘No IMPs are attached’ is displayed. In this case you should check that the IMPs are connected correctly.)

IMPOLL then synchronizes the IMP calendars with the PC internal clock, and starts polling the IMPs. After a few seconds the result of the poll is displayed, in the Receive Poll Table (Figure 3.2).

IMP		Stream				IMP		Stream			
		0	1	2	3			0	1	2	3
1	3595 1A	OK	OK	OK	OK	16	3595 2A	OK	OK	OK	OK
2	3595 2A	DATA	OK	OK	OK	17					
3	3595 1A	DATA	OK	OK	OK	18	3595 1B	DATA	OK	OK	OK
4	3595 1C	OK	OK	OK	OK	19	3595 1B	DATA	OK	OK	OK
5						20	3595 1B	DATA	OK	OK	OK
6	3595 1C	OK	OK	OK	OK	21	3595 1B	DATA	OK	OK	OK
7	3595 2A	OK	OK	DATA	OK	22	3595 1B	DATA	OK	OK	OK
8	3595 2A	OK	OK	DATA	OK	23					
9	3595 1C	OK	OK	OK	OK	24	3595 1A	OK	OK	OK	OK
10						25	3595 1A	OK	OK	OK	OK

F1 to transmit    F2 to receive    F3 to clear                      F9 colors    F10 to end

**Figure 3.2 The Receive Poll Table**

The meanings of the various stream responses, for example ‘OK’ and ‘DATA’, are explained in Table 3.1.

**Table 3.1 Receive Poll Responses**

Response	Meaning
OK	Shows that the IMP has been polled, but has no data ready in this particular stream.
DATA	Shows that the IMP has data ready in this particular stream. (A ‘DATA’ response is displayed only after the IMP has been commanded to make a measurement.)
ERR	Shows that the IMP no longer responds to polling, or that a break in the IMP’s response to a poll has occurred. The actions to be taken for an ERRor response are listed in Table 3.1 (in Section 7).

Each time an IMP responds to a command the Receive Poll Table is updated. For example, when IMP2 responds to a measurement command 'OK' in the Stream 1 column for that IMP is replaced by 'DATA'.

## 4 USING THE IMPOLL FUNCTIONS

---

As indicated by the legends at the bottom of the Receive Poll Table, you can:

- press key **F1** and send commands to an IMP, or
- press key **F2** and read data sent by an IMP, or
- press key **F3** and clear a communications error, or
- press key **F9** and set screen colors, or
- press key **F10** and exit IMPOLL.

The use of each of these functions is described below, in Sections 4.1 through 4.5.

### 4.1 SENDING IMP COMMANDS (FUNCTION F1)

The procedure for sending IMP commands is as follows:

1. Press key **F1**.

*If there is more than one IMP operational on S-Net, IMPOLL prompts you for the address of the IMP that is to receive the commands.*

2. When prompted, type in the address of the IMP to be commanded and press the return key. (An address of 0 causes the commands to be sent to all the IMPs on your system.)

*IMPOLL now prompts you for the commands to be sent.*

3. Type in the command(s) to be sent and press the return key. Typical command strings and their actions are listed in Table 3.2. Note that you can send IMP commands in a string or as a series of single commands. Normally command strings are used for data acquisition and single commands are used for fault-finding.

**Table 3.2 Typical IMP Command Strings**

Command String	IMP Type	IMP Actions
SE;TR	Analog	Sets the IMP for 'volts dc auto-ranging' and arms the IMP to make measurements.
SE;TR	Digital	Sets the IMP for 'digital status' and arms the IMP to make measurements.
RE;CH1MO103;AR;ME1	Analog	Resets previous settings, sets channel 1 to 'volts dc 2V range', arms the IMP and then tells the IMP to take a measurement on Channel 1. Single channel measurements are returned in Stream 1 so, when the measurement is completed, the word 'DATA' appears in the stream 1 column against each IMP to which the command string has been sent. A subsequent ME1 command (on its own, or in another command string) starts another measurement on channel 1.
RE;CH1MO902;AR;ME1	Digital	Resets previous settings, sets channel 1 to 'frequency measurement - gate time 1 second', arms the IMP and then tells the IMP to take a measurement on Channel 1. Single channel measurements are returned in Stream 1 so, when the measurement is completed, the word 'DATA' appears in the stream 1 column against each IMP to which the command string has been sent. A subsequent ME1 command (on its own, or in another command string) starts another measurement on Channel 1.
SE;CO;TR	Analog/ Digital	Quick setup: sets up all channels on all IMPs. Analog channels are set for 'volts dc auto-ranging', whilst digital channels are set for 'digital status'. All IMPs begin continuous scanning and continue until either the available buffers are full or a HA (halt) command is sent. <b>Note:</b> When you use Function 2 to receive a scan, and the buffers are full, IMPOLL makes buffer space available to enable the scan data to be received.
HA	Analog/ Digital	Cancels the continuous measurement mode. Should an IMP be part way through a scan when it receives an HA command then it will continue to the end of the scan, otherwise the mode is cancelled immediately.

A full description of all IMP commands is contained in Part 2 of the manual.

#### 4.1.1 Extending a Command String to Cover All Channels

A command string can be extended to set up every channel on an IMP and then command a scan. For this, the string should contain a CH MO for each channel. As an example, a string of twenty CH MO commands could be sent to an IMP type 3595 1A:

```
RE;CH1MO100;CH2MO500; ..... ;CH20MO310;AR;TR
```

Any channel that a command string omits to set up defaults to 'skip' and, instead of returning a measurement when the scan is started (by the TR command), returns the message 'Not measured'.



Although most number in IMP commands are sent as ASCII (keyboard) characters, there are some that must be sent in IEEE format. For these IMPOLL provides an automatic conversion facility.

For example, the TE (set external temperature reference) command should be followed by the reference temperature as an IEEE number, which would be difficult (if not impossible) to send from the keyboard (involving control characters etc.). To send the IEEE numbers from IMPOLL, however, simply enclose the typed-in value of the number in single quotes (apostrophes), for example:

TE'25'      which sets the external temperature reference to 25°.

IMPOLL does not support the commands LO or SA. These commands are concerned with loading or saving IMP set-up data in bulk. IMPOLL has no facility for handling the long character strings required by these commands.

## 4.2 RECEIVING IMP DATA (FUNCTION F2)

The procedure for receiving data from an IMP is as follows:

1. Press key **F2**.

*If there is more than one IMP on the system, IMPOLL prompts for the address of the IMP from which data is to be received.*

2. When prompted, type in the appropriate IMP address and press the return key.

*IMPOLL now prompts for the stream in which the required data is available.*

3. Select a stream in which the word 'DATA' is displayed against the IMP selected in step 2. To do this, type in the stream number and press the return key. The data types conveyed in each stream are listed in Table 3.3.

**Table 3.3 Streamed Data Types**

Stream #	Data Type
0	Scanned (multi-channel) data. Data in this stream is display on the Receive Scan Table (Figure 3.3).
1	Single-channel data, or two numbers representing a command response. Values read from this stream are displayed on the Receive Poll Table (under 'Result'), either as number(s) or as a brief IMP error message. For an explanation of IMP error messages refer to Part 2, Chapter 2, of the manual.
2	Event information, sent only by Digital IMPs (3595 2A and 3595 2B). Data in this stream is displayed on the Receive Event Table (Figure 3.4).
3	Character (ASCII) data, sent by IMPs in response to some commands. For example., requests for SStatus or to HAlt. Characters read from this stream are displayed on the Receive Poll Table (under 'Result').

In the case of a single channel measurement the measurement value (or an error message) is displayed against 'Result:-' at the bottom of the Receive Poll Table.

When IMPOLL wishes to display Stream 0 (multiple measurement) data, however, it switches to the Receive Scan Table (see Section 4.2.1). Similarly, to display Stream 2 (event) data IMPOLL switches to the Receive Event Table (see Section 4.2.2). In each case you can return to the Receive Poll Table by using Function F7 (exit table).

The date and time displayed on the Receive Poll, Receive Scan and Event Scan Tables are derived from the PC internal clock (BASIC variables DATE\$ and TIME\$). Both can be updated by the real-time clock board (if fitted) on power-up.

### 4.2.1 Reading a Data Scan

Scanned data, from Stream 0, is displayed on the Receive Scan Table (Figure 3.3).

Displayed at the top of the table are: the present date and time, the address of the presently selected IMP, and the IMP type number.

Under this is the 'STREAM STATUS', which is an extract from the Receive Poll Table (see Section 4.1). The status of Streams 0 through 3 for the selected IMP is shown, from left to right, in exactly the same way.

Numeric data, or a shortened IMP error message, is shown against each channel. An explanation of IMP error messages is given in Part 2, Chapter 2, of the manual.

04-SEP-1992		RECEIVE SCAN TABLE				14:57:19	
IMP NUMBER: 3 TYPE: 3595 1A							
STREAM STATUS		DATA	OK	OK	OK		
CHAN	DATA	CHAN	DATA				
1	-0.11212	11	0.000001				
2	-0.05238	12	Not measured				
3	Linearization	13	0.000003				
4	0.000001	14	0.000125				
5	0.000001	15	0.000001				
6	0	16	24.2				
7	0	17	8.0125				

F1 to transmit    F2 to receive    F3 to clear    F4 to update    F5 continuous  
F7 to exit table

**Figure 3.3 The Receive Scan Table**

With the Receive Scan Table displayed you can:

- press **F1** and send commands to the *presently selected* IMP, or
- press **F2** and read data from the *presently selected* IMP, or
- press **F3** and clear a communications error from the *presently selected* IMP, or
- press **F4** and read the next scan, if available, or
- press **F5** and continuously update the screen, or
- press **F7** to exit the Receive Scan Table and return to the Receive Poll Table.

Functions **F1**, **F2**, and **F3** act in the same way as when the Receive Poll Table is displayed, except that they can be applied only to the presently selected IMP. (These functions are described in Sections 4.1 through 4.3.)

Should you wish to address a different IMP then you must press key **F7** to return to the Receive Poll Table.

Pressing key **F4** prompts IMPOLL to read the next scan from an IMP and update the display. If no new scan is available, then the last scan displayed is erased. Before using this option, you should check that data is available. That is, when DATA is displayed in the leftmost column of the 'STREAM STATUS' line.

Pressing key **F5** prompts IMPOLL to update scanned data automatically, as it is sent back by the IMP. The only IMPOLL function then available is 'F6 to stop'. Press key **F6** when you wish to stop automatic updating and return to the original function set.

## 4.2.2 Reading Digital 'Events'

Digital event data, from Stream 2, is displayed on the Receive Event Table (Figure 3.4).

Displayed at the top of the table are: the present date and time, the address of the presently selected IMP, and the IMP type number.

Under this is the 'STREAM STATUS', which is an extract from the Receive Poll Table (see Section 4.1). The status of Streams 0 through 3 for the selected IMP is shown, from left to right, in exactly the same way.

Up to 28 events may be displayed, each with the date and time at which it occurred. (The year of an event is not sent by an IMP, although it is used within the IMP for setting leap years etc.)

Under the heading 'CHAN.' appears the channel number of an event.

Under the heading 'EVENT': 'Lo to Hi' indicates that a positive-going transition was captured; 'Hi to Lo' indicates that a negative-going transition was captured; 'High' or 'Low' indicate the state of an input channel.

04-SEP-1992		RECEIVE EVENT TABLE				14:40:05	
IMP NUMBER: 7 TYPE: 3595 2A							
STREAM STATUS		OK	OK	DATA	OK		
DATE	TIME	CHAN.	EVENT	DATE	TIME	CHAN.	EVENT
dd-mmm hh:mm:ss.ms				dd-mmm hh:mm:ss.ms			
04-SEP	14:39:55.075	01	Hi to Lo				
04-SEP	14:39:56.075	01	Lo to Hi				
04-SEP	14:39:56.077	02	Lo to Hi				
04-SEP	14:39:56.577	02	Hi to Lo				
04-SEP	14:40:01.043	05	Hi to Lo				
04-SEP	14:40:01.044	07	Hi to Lo				
04-SEP	14:40:04.843	07	Lo to Hi				
04-SEP	14:40:05.018	05	Lo to Hi				
04-SEP	14:40:06.216	08	High				
04-SEP	14:40:06.216	09	Low				

F1 to transmit    F2 to receive    F3 to clear    F4 to update  
F7 to exit table

**Figure 3.4 The Receive Event Table**

With the Receive Event Table displayed you can:

- press **F1** and send commands to the *presently selected* IMP, or
- press **F2** and read data from the *presently selected* IMP, or
- press **F3** and clear a communications error from the *presently selected* IMP, or
- press **F4** and read the next scan, if available, or
- press **F7** to exit the Receive Event Table and return to the Receive Poll Table.

Functions **F1**, **F2**, and **F3** act in the same way as when the Receive Poll Table is displayed, except that they can be applied only to the *presently selected* IMP. (These functions are described in Sections 4.1 through 4.3.)

Should you wish to address a different IMP then you must press function key **F7** to return to the Receive Poll Table.

Pressing function key **F4** prompts IMPOLL to read the next set of event data from an IMP and update the display. If no new scan is available, then the last scan displayed is erased. Before using this option, you should check that data is available. That is, when 'DATA' is displayed in the third column from the left in the 'STREAM STATUS' line.

### 4.3 CLEARING 'ERR' (ERROR) INDICATIONS (FUNCTION F3)

If a communications error occurs, for example, a temporary disconnection of the S-Net cable at one IMP, then 'ERR' is displayed against the offending IMP/Stream combination. If the error disappears, the screen continues to display 'ERR' and no data can be received from this IMP/Stream combination. The error message can be cleared and operation returned to normal, provided the communications error is only temporary.

The procedure for clearing 'ERR' indications is as follows:

1. Press key **F3**.

*If more than one IMP is on the system, IMPOLL prompts for the address of the IMP to have its errors cleared.*

2. When prompted, type in the appropriate IMP address and press the return key. Using an address of '0' clears errors from every IMP on the system.

### 4.4 ADJUSTING THE DISPLAY COLORS (FUNCTION F9)

Function F9 allows you to adjust the foreground and background colors of the screen text, highlighted text, and error message text.

The default colors are:

Screen text : Light green foreground, black background.

Highlighted text : White foreground, black background.

Error Message text : Bright red foreground, black background.

The procedure is as follows:

1. Press key F9.
2. Use the arrow keys (on keyboard) to select the text whose color you intend to change.
3. Use the arrow keys to select the desired color.
4. Press the return key to enter your selected color.
5. Repeat steps 2 through 4 for the texts you wish to adjust.

When you have adjusted the display colors to your satisfaction you can return to the Receive Poll Table by pressing the **Esc** (escape) key.

### 4.5 EXITING IMPOLL (FUNCTION F10)

When you wish to exit IMPOLL press key F10. The DOS prompt is then displayed.

## 5 FAULT DIAGNOSIS

---

If operation of the PC and S-Net system is suspect you can use IMPOLL for fault diagnosis. First, however, check that the system requirements are met, as detailed in Chapter 1, Section 1.1.

The procedure is:

1. Restart the system by loading the DOS (system) diskette into the default drive, usually drive A.
2. Switch the PC off and on again, or press –and release simultaneously– the ‘ctrl’, ‘alt’ and ‘del’ keys. This should load DOS (which may take some time). When DOS is loaded the DOS prompt (default drive letter following by ‘>’) is displayed.
3. Remove the DOS diskette and follow the instructions given in Chapter 3 for running IMPOLL.EXE. Fault symptoms and the relevant diagnosis checks are listed Table 3.1.

**Table 3.4 Fault Diagnosis and Elimination**

Symptom	Diagnostic Checks	Manual Reference
IMPOLL returns message 'Interface not found at any standard location'.	<p>Check:</p> <ol style="list-style-type: none"> <li>(1) Base address of Interface, setting of switches SW101 and SW102.</li> <li>(2) Addresses used by other option cards -if necessary change the base address of Interface and modify any programs to suit new base address.</li> </ol>	<p>Part 1 Ch. 2, Section 3  Ch. 2, Section 3</p>
IMPOLL fails to locate any IMP(s) - no 'OK' or 'ERR' displayed against IMP(s) - or message 'No IMPs are attached' displayed.	<p>Check:</p> <ol style="list-style-type: none"> <li>(1) IMPs and PC are connected correctly.</li> <li>(2) Polarity, fuse, and connection of any external supply (if used).</li> <li>(3) IMP front panel LED should be lit if the IMP has powered up correctly. A flickering LED indicates a low or intermittent supply.</li> <li>(4) The external supply must be capable of supplying the correct number of IMPs the required distance with the gage of cable used.</li> <li>(5) also, the items under 'transmit and receive errors'.</li> </ol> <p><b>Note:</b> If the S-Net connections are reversed; analog and 2B IMPs will not power-up, 2A IMPs will power-up but will not communicate with the interface.</p>	<p>Part 1 Ch. 2, Section 10 and IMP Installation Guide. Ch. 2, Section 10 and Ch. 5 IMP Installation Guide  Ch. 2, Sections 9 and 10</p>
Transmit or receive errors are reported.	<p>Check:</p> <ol style="list-style-type: none"> <li>(1) Termination of the S-Net.</li> <li>(2) Correct settings of each IMP address (on connector block) No IMPs should be set to the same address.</li> <li>(3) Power supply must be capable of supplying the required power for the size of the system.</li> <li>(4) Ripple on the external power supply must not exceed 100mV rms.</li> <li>(5) Any possible sources of interference.</li> </ol>	<p>Part 1 Ch. 2, Section 10 and IMP Installation Guide. IMP Installation Guide  Ch. 2, Sections 9 and 10</p>
Unexpected, spurious, or miscellaneous faults, or program crashes.	<p>Check:</p> <ol style="list-style-type: none"> <li>(1) Items as 'transmit or receive errors', as above.</li> <li>(2) Interrupt select links on interface-all links should be open for IMPOLL program.</li> <li>(3) Diskette is not corrupted, by verifying the diskette.</li> <li>(4) The PC. Try running other software. Remove interface and try again, if necessary. If the interface appears to interfere with programs try changing its base address.</li> </ol>	<p>Part 1  Ch. 2, Section 5  Ch. 1, Section 11  Ch. 2, Section 3.2</p>





# Programming the 3595 4B Interface

## Contents

<b>1</b>	<b>Introduction</b> .....	4-5
<b>2</b>	<b>Addressing the Interface Memory</b> .....	4-5
2.1	Using Memory-Mapped Addressing .....	4-5
2.2	Using Port-Mapped Addressing .....	4-7
<b>3</b>	<b>Controlling IMP Communication</b> .....	4-10
3.1	Initializing the System .....	4-11
3.2	Transmitting a Command Message .....	4-12
3.3	Receiving Measurement Results .....	4-12
3.4	Using Interrupts .....	4-13
<b>4</b>	<b>Interface Control</b> .....	4-14
4.1	Interface Control Register .....	4-14
4.2	Interface Operating Mode .....	4-15
4.3	Extended Error Codes .....	4-15
4.4	Software Status And Issue .....	4-15
4.5	Flash Checksum .....	4-16
4.6	Real-Time Calendar and Clock .....	4-16
4.7	Selecting IMPs for Polling .....	4-19
4.8	Selecting the RAM Pages .....	4-19

4.9	Transmitting Data to the IMPs .....	4-20
4.10	Reading the Received Data Status .....	4-22
4.11	Setting Receive Interrupts .....	4-23
<b>5</b>	<b>Dual Redundancy Control .....</b>	<b>4-24</b>
5.1	Dual Redundancy Control Register .....	4-25
5.2	Dual Redundancy Programming .....	4-26
5.3	Failure Detection .....	4-28
5.4	Failure Recovery .....	4-29
<b>6</b>	<b>Receiving Imp Results And Responses .....</b>	<b>4-30</b>
6.1	Data Streams .....	4-31
6.2	Stream Size .....	4-31
6.3	Stream Time Tags .....	4-32
6.4	Transmit Retry Count .....	4-32

### **List of Figures**

<i>Figure 4.1</i>	<i>RAM page access by the Host PC .....</i>	<i>4-4</i>
<i>Figure 4.2</i>	<i>Comparison between memory-mapped and port-mapped addresses .....</i>	<i>4-7</i>
<i>Figure 4.3</i>	<i>Interface control register. ....</i>	<i>4-14</i>
<i>Figure 4.4</i>	<i>Real-time calendar and clock. ....</i>	<i>4-16</i>
<i>Figure 4.5</i>	<i>Poll table. ....</i>	<i>4-19</i>
<i>Figure 4.6</i>	<i>Transmit registers. ....</i>	<i>4-20</i>
<i>Figure 4.7</i>	<i>Receive table. ....</i>	<i>4-22</i>
<i>Figure 4.8</i>	<i>Receive interrupt table. ....</i>	<i>4-23</i>
<i>Figure 4.9</i>	<i>Typical dual-redundancy system. ....</i>	<i>4-24</i>
<i>Figure 4.10</i>	<i>Dual Redundancy Control Register .....</i>	<i>4-25</i>
<i>Figure 4.11</i>	<i>Stream size locations. ....</i>	<i>4-31</i>
<i>Figure 4.12</i>	<i>Stream time tag locations. ....</i>	<i>4-32</i>

## **List of Tables**

<i>Table 4.1</i>	<i>Port Functions</i> .....	4-7
<i>Table 4.2</i>	<i>Page to Sector Address Conversion</i> .....	4-8
<i>Table 4.3</i>	<i>Control and Status Areas of RAM Page 0</i> .....	4-10
<i>Table 4.4</i>	<i>Flash Checksum Registers</i> .....	4-16
<i>Table 4.5</i>	<i>Failure Recovery Strategies for Dual Redundancy Systems</i> .....	4-29
<i>Table 4.6</i>	<i>Content of RAM Pages 2 through 51</i> .....	4-30
<i>Table 4.7</i>	<i>Data to Stream Assignments</i> .....	4-31

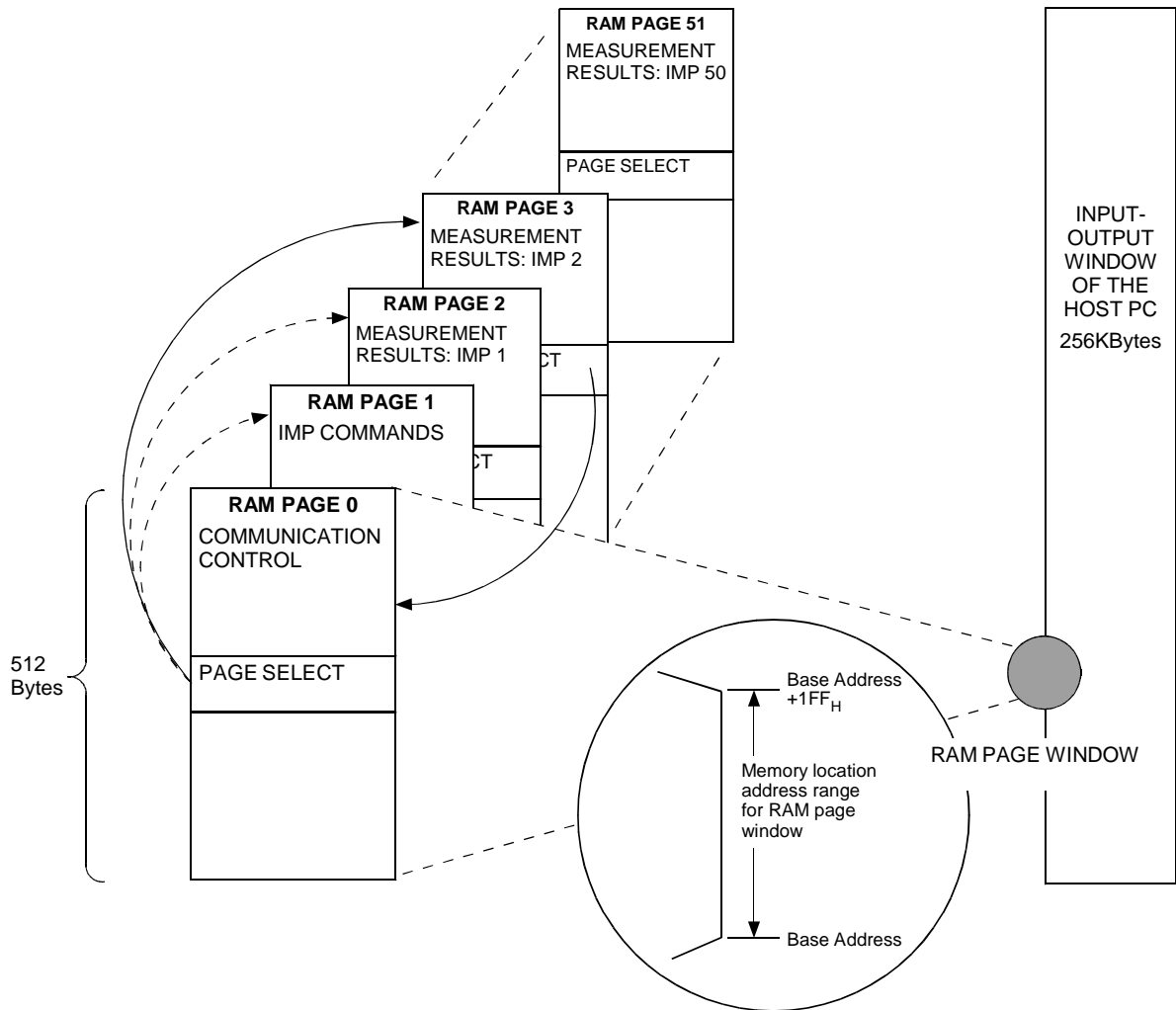

**Figure 4.1 RAM page access by the Host PC**

# 1 INTRODUCTION

---

This chapter describes how the Host PC can be made to control the IMPs on S-Net by accessing a 64K dual-port RAM on the 3595 4B Interface. The information is intended for users who wish to write their own software drivers: if your system uses Solartron Instruments software then the dual-port RAM is 'transparent' and you need not get involved with it.

## 2 ADDRESSING THE INTERFACE MEMORY

---

By accessing the Interface memory the Host PC is able to communicate both with the 3595 4B Interface itself and with the IMPs under its control.

The memory locations can be addressed in either of two modes: memory-mapped or port-mapped. Each mode is described below.

### 2.1 USING MEMORY-MAPPED ADDRESSING

Figure 4.1 shows how the interface dual-port RAM is divided up into 512-byte pages, each page dealing with a particular aspect of IMP operation.

**Communication control** is managed through RAM Page 0. On this page the Host PC controls such things as:

- IMP command transmission,
- the polling of IMPs for data,
- measurement data and message reception, on the IMP data streams,
- real-time calendar and clock control of the '4B Interface,
- S-Net power on/off, and
- Dual Redundancy.

**IMP commands** to be transmitted are written by the Host PC into RAM Page 1.

**Measurement results** from the IMPs are received on RAM Pages 2 through 51, which are assigned to IMPs 1 through 50.

#### 2.1.1 Addressing The Interface Ram Locations

The Host PC accesses the dual-port RAM of the '4B Interface through the *RAM page window* (Figure 4.1). This window stands on a switch-selectable *base address* and is 200<sub>H</sub> locations wide. The width of the window allows it to encompass one complete RAM page. Initially the page accessed is Page 0. Any other page can be accessed from this by writing the appropriate page number into the *page select* location on Page 0

The base address is defined by switch settings on the '4B Interface (See Chapter 2). This address can be set in the range 80000<sub>H</sub> through FFE00<sub>H</sub>, at a resolution of 200<sub>H</sub> – for example: 80000<sub>H</sub>, 80200<sub>H</sub>, 80400<sub>H</sub>, and so on. This provides for a page size of 200<sub>H</sub> (=512<sub>10</sub>) bytes.

Taking the base address of 80400<sub>H</sub> as an example, the memory location addresses used by the Host PC will be:

80400<sub>H</sub> through 805FF<sub>H</sub>

The address of the page select byte is  $base\ address_{H}+FF_{H}$  which, in the present example, is 804FF<sub>H</sub>.

A return to RAM Page 0 from the page in use is made by reading the page select byte. The data read is the actual data at this location (a measurement data byte on RAM Page 2 for example). On RAM Page 0, however, the page select byte contains the number of the page returned from. This number can be saved, should the page returned from need to be restored. (See Section 2.1.2.) Zero should then be written into the page select byte to indicate that RAM Page 0 is selected.

### 2.1.2 Restoring A Previously Selected Ram Page

In a multi-task program it may be necessary to restore a RAM page for Task A on completion of Task B. The routine for doing this is as follows:

1. Use Task B to read the PAGE SELECT byte on the page presently used by Task A.
2. Read the PAGE SELECT byte again. This will contain the number of the page used by Task A.
3. Save this page number.
4. Write zero to the PAGE SELECT byte to indicate that RAM Page 0 is now selected. (**Note:** This ensures that RAM Page 0 will be restored for Task B, should it be interrupted whilst using Page 0.)
5. On completion of Task B select RAM Page 0 by reading the PAGE SELECT byte on the page in use.
6. Get the page number saved in step 3.
7. Write this page number into the PAGE SELECT byte. The RAM Page previously selected for Task A is now restored.

During the above sequence, interrupts should be masked. This is to cover the period when RAM Page 0 is selected but the PAGE SELECT byte still contains the previous page number.

## 2.2 USING PORT-MAPPED ADDRESSING

When operated in port-mapped mode the '4B Interface occupies 16 consecutive port addresses. (Port addresses are assigned by hardware switch settings, as described in Chapter 2 of the manual.)

Port-mapped operation gives direct access to the ports listed in Table 4.1.

**Table 4.1 Port Functions**

Port Address*	Port Function
---00 <sub>H</sub>	Interface Control (r/w)
---04 <sub>H</sub>	Sector number, least sig. byte (r/w)
---05 <sub>H</sub>	Sector number, most sig. byte (r/w)
---06 <sub>H</sub>	Sector offset (r/w)
---0E <sub>H</sub>	Dual Redundancy Control (r/w)
---0F <sub>H</sub>	Data Transfer (r/w)

\* To obtain the actual port addresses used, add these addresses to the base address.

### 2.2.1 Sector Addresses

Sector addresses are similar to the page addresses (described in Section 2.1) and may be derived from them. Figure 4.2 compares these two address types.

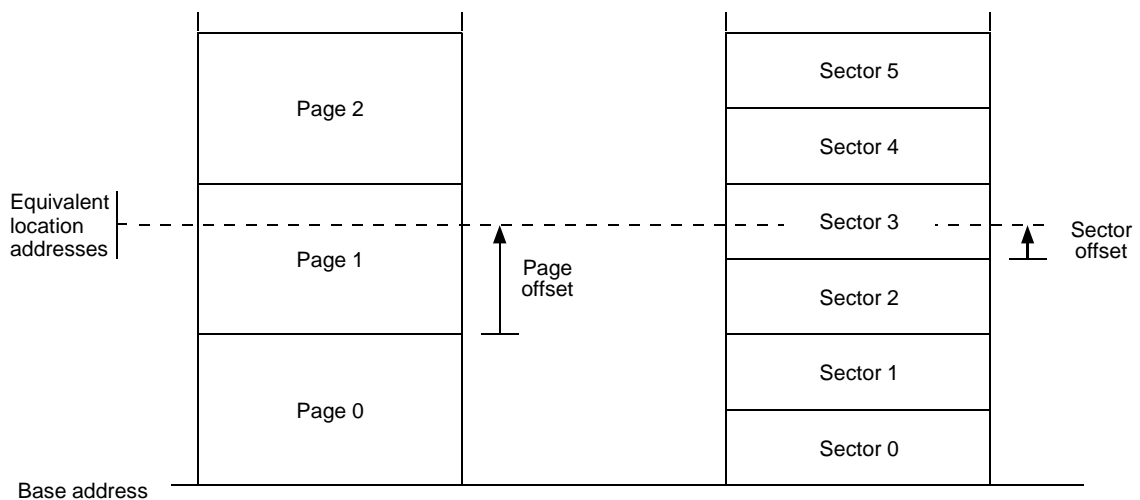

**Memory-mapped addressing:**

Location address: page number and offset

**Port-mapped addressing:**

Location address: sector number and offset

**Figure 4.2 Comparison between memory-mapped and port-mapped addresses**

Whether you use memory-mapped or port-mapped addressing you are accessing the same area of memory within the Interface dual-port RAM.

Figure 4.2 shows the similarities and the differences. In memory-mapped addressing the RAM is divided into 512 (200<sub>H</sub>) byte *pages*, and a memory location is addressed by specifying a page number and an offset within that page. In port-mapped addressing the RAM is divided into 256 (100<sub>H</sub>) byte *sectors*, and a memory location is addressed by specifying a sector number and an offset within that sector.

Two RAM *sectors* fit neatly onto each RAM *page*, which allows the sector number and sector offset for a particular location to be easily derived from the corresponding page number and page offset. Table 4.2 shows you the conversions. These can be applied to the memory-mapped addresses listed throughout this chapter, to get the corresponding port-mapped addresses.

**Table 4.2 Page to Sector Address Conversion**

	Page offset < 100 <sub>H</sub>	Page Offset ≥ 100 <sub>H</sub>
<b>Sector Number</b>	= 2 × page number	= 2 × page number + 1
<b>Sector Offset</b>	= page offset	= page offset - 100 <sub>H</sub>

For example, you may wish to know the sector number and sector offset of the first byte of Data Stream 2 from IMP 2. Section 2.1 shows that the results from IMPs 1 through 50 are stored on pages 2 through 51: therefore we know that the results from IMP 2 are stored on RAM Page 3. From Table 4.6 we see that the page offset for the first byte in Stream 2 is 080<sub>H</sub>. Therefore, from Table 4.2 the required sector number is 2 × 3 (=6) and the sector offset is the same as the page offset – that is, 080<sub>H</sub>.

To provide for fast programming the sector offset is automatically incremented after each access to the Data Transfer Port. This facility, in conjunction with the ‘rep’ instruction of the PC’s 80×86 processor, can be used to move data quickly.

**Example:**

*The Interface is set for port addresses 100<sub>H</sub> through 10F<sub>H</sub>. To access the first four bytes of data in Stream 2 from IMP2 the following sequence of assembler instructions is required:*

```

mov     al, 6                ; Sector number lo
out     al, 104h
mov     al, 0                ; Sector number hi
out     al, 105h
mov     al, 128              ; Sector offset
out     al, 106h

cld
mov     cx, 4                ; Clear direction flag (work upwards)
mov     di, OFFSET buffer    ; 4 bytes to transfer
mov     dx, 10Fh             ; where to put the data
rep     insb

```



### 2.2.2 Reversing the Data Byte Order

To ensure compatibility with the '4A Interface the IMP results are stored in the '4B Interface in IEEE floating-point format, with 'big-endian' byte ordering. (This is the byte order used by Motorola, in which the most significant byte is output first.) To simplify the interpretation of these results by the PC it is possible to set the '4B Interface to reverse the byte order. The byte order thus obtained is 'little-endian', in which the least significant byte is output first. (This is the byte order used by an Intel processor.)

The byte order is reversed by setting bit 4 in the Interface Control Register (see Section 4.1) and transferring each four-byte data word from a long word boundary.

### 3 CONTROLLING IMP COMMUNICATION

The Host PC controls IMP communication by accessing RAM Page 0. This page holds 512 bytes of control and status information for up to 50 IMPs. Table 4.3 lists the control facilities on RAM Page 0 and the range of location addresses used for each one. The use of these facilities is described in Section 3.1 (p 4-11). The bit functions are described in Section 4 (p 4-14).

**Table 4.3 Control and Status Areas of RAM Page 0**

Location Addresses* (hex)	Function
000 - 0C7 (r/w)	Receive Table
0C8 - 0CE (r/w)	Poll Table (Receive Enable)
0CF - 0E7 (r/w)	Receive Interrupt Table
0E8 - 0ED (r/w)	Transmit Control Registers
0EE - 0F7 (r/w)	Real-time Calendar and Clock
0F8 - 0FE (r/w)	Reserved
0FF (r/w)	Page Select
100 - 1FF (w)	Interface Control Register
100 (r)	Interface Control Register (as Port 00)
101	Reserved
102 (r)	Dual Redundancy Status Register (as Port 0E)
103	Reserved
104 (r)	Operating Mode
105 (r)	Extended Error Codes
106 - 10F	Unallocated
110 (r)	Boot Software Status (in ASCII, e.g. 'A')
111 (r)	Boot Software Issue (in ASCII, e.g. 'B')
112 (r)	Main Software Status (in ASCII, e.g. 'A')
113 (r)	Main Software Issue (in ASCII, e.g. 'G')
114 - 11F	Reserved for extra software information
120 - 128 (r)	Flash Checksum
129 - 140	Reserved
141 - 1FF	Unallocated

\* To obtain the actual location addresses used, add these addresses to the base address.

## 3.1 INITIALIZING THE SYSTEM

To initialize the system the Host PC must set up:

- The **INTERFACE CONTROL REGISTER** (Section 4.1, p 4-14). This provides for:
  - powering up S-Net (where IMPs are powered from the Interface) and indirectly resetting the IMPs,
  - resetting the Interface,
  - selecting ‘little-endian’ or ‘big-endian’ byte ordering for port mode data transfers,
  - reprogramming the ’4B Interace in-situ,
  - reading an error code.
- The **REAL-TIME CALENDAR AND CLOCK** (Section 4.6, p 4-16). Once this is done the time is transmitted to all IMPs on the network, once every second. This maintains the time in all IMPs, accurate to within  $\pm 1$ ms of the time in the Interface.
- The **POLL TABLE** (Section 4.7, p 4-19). In this table a bit should be set for each IMP from which data is required. Alternatively, the Poll Table may be set later, when reception is required.

### **NOTE: Power Up Settling Delay**

After power has been applied to the S-Net, the IMPs take time to become fully operational. For 50V at the IMP, this time could be up to 1 second, whereas for 10V, it is up to 3 seconds. The voltages quoted are those actually at the IMP, not those applied to the S-Net at the Controller. The times quoted apply to IMPs *other than* UIMPs: for UIMPs the times should be doubled.

Setting poll bits before the power up time has elapsed can result in poll errors being generated. Therefore it is necessary to delay setting up the poll table by a time slightly in excess of the power up time.

- If Interface is part of a dual redundancy system, the **DUAL REDUNDANCY CONTROL REGISTER** (Section 5.1, p 4-25). The use of a typical dual redundancy system is described in Section 5, page 4-24.

The Interface can now be used to command the IMPs on S-Net and receive data from them. Sections 3.2 through 3.4 tell you how.

## 3.2 TRANSMITTING A COMMAND MESSAGE

To make an IMP do something the Host PC sends it a command message. This is loaded into **RAM Page 1**, which can hold up to 256 bytes. (Details of the IMP commands are given in Part 2 of the manual.)

To control message transmission the Host PC uses the **TRANSMIT REGISTERS** (Section 4.9, p 4-20). These allow the Host PC to:

- specify the number of bytes to be transmitted,
- specify the address of the IMP to which the message is to be sent,
- communicate with the Interface regarding:
  - transmission requests,
  - transmission errors,
  - transmission busy, and
  - ‘break’ character transmission (for resetting locally powered IMPs).
- specify whether it wants to be interrupted at the end of transmission.

## 3.3 RECEIVING MEASUREMENT RESULTS

Measurement data is received only from those IMPs selected in the **POLL TABLE** (Section 4.7, p 4-19). The Interface polls each of these IMPs in turn.

When an IMP has data ready to send back to the Interface, it responds to a poll by placing the data on the S-Net. If the data is received successfully the Interface places it in the RAM page for measurement results relating to the IMP. The Interface then sets the Data Ready (DR) bit and Data Offset for that IMP and stream, in the **RECEIVE TABLE** (Section 4.10, p 4-22). If the data offset in this table is multiplied by four, it gives the address within the IMP’s data page at which the received data is to be found.

When measurement data has been read by the Host PC, the relevant entry in the **RECEIVE TABLE** should be cleared. This allows the Interface to receive further measurement data from the IMP and stream.

Data can be received on four streams from each IMP and should reception fail on any stream then the Interface tries three more times to receive data before reporting an error. The Interface reports errors by setting the Receive Data Error bit (RXE) in the **RECEIVE TABLE** for each active stream of the IMP that is being polled.

For all IMPs the Host PC can enable interrupts on selected data streams by setting the relevant bits in the **RECEIVE INTERRUPT TABLE** (Section 4.11, p 4-23). On streams for which interrupts are enabled an interrupt is generated by the Interface, either when data is successfully received or when a receive error is reported.

### 3.4 USING INTERRUPTS

The '4B Interface is able to interrupt the Host PC for the following things:

- Transmit complete
- Calendar access granted
- Measurement data received, for each of four data streams on up to 50 IMPs.
- Poll fail, with the '4B Interface in dual-redundancy monitor mode.

Whilst any of these conditions exists, and an interrupt is enabled, the Interface continues to interrupt the Host PC. Therefore special processing of interrupts may be necessary if the Host PC is to be able to service all sources of interrupt and not just one or two busy ones.

It is recommended that, once a source of interrupt has gained the attention of the Host PC, any further interrupts from the same source are disabled until other equally important interrupts have been attended to.

## 4 INTERFACE CONTROL

### 4.1 INTERFACE CONTROL REGISTER

The Interface Control (IC) register (Figure 4.3) appears on two RAM pages, Page 0 and Page 255. On both pages the register is located at address  $--100_H$ .

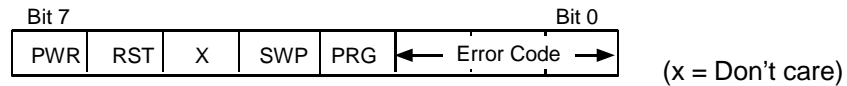

**Figure 4.3 Interface control register.**

To ensure software compatibility between the '4A and '4B Interfaces, the only function that can be controlled from RAM Page 0 is the PWR function (bit 7). On RAM Page 255 *all* functions can be controlled. On both RAM pages the state of all bits in the IC register may be read.

The bit functions of the IC register are:

**PWR** Power to S-Net: '1' = power on; '0' = power off.

*IMPs can be reset by switching the power off and on again. To ensure that power is completely removed from the IMPs, insert a 250ms delay between these two actions. Note that IMPs that are powered locally can be reset by sending a 'Break' command from the Transmit Control Register (Section 3.2, p 4-12)*

*Allow a delay of 3s after power up before attempting to communicate with the IMPs. For UIMPs, allow a delay of 6s.*

**RST** Interface reset: '0' = reset; '1' = unreset.

**SWP** Swap byte ordering. (Applicable only to port mode. See Section 2.2.2.)

**PRG** Programming mode. Should it be necessary, the '4B Interface can be reprogrammed in-situ using the program PROG4B.EXE. The programming information is stored in file 35954B.S2, which contains Motorola S-record data.

**Error code** The meanings of the error codes that may appear in bits '0' through '2' are as follows:

- 0 =No error.
- 1 =Dual port RAM error.
- 2 =Local RAM error.
- 3 =Boot code ROM error.
- 4 =Main code ROM error.
- 5 =Firmware failure. (Watchdog has reset the '4B Interface.)
- 6 =Host software failure. See Sections 5.3 and 5.4 for further information.
- 7 =General error. See Section 4.3 for extended error codes.

Error codes 1 through 5 indicate that a '4B hardware error has occurred. Therefore, you should return the '4B for repair. (Please give the error code detected as this will help in the fault finding.)

## 4.2 INTERFACE OPERATING MODE

A '4B Interface may be operated in any one of three modes, as indicated by the following codes in RAM location --104<sub>H</sub>:

- 1 =enhanced '4A mode (up to 50 IMPs, time-tagged and sized results),
- 2 =dual-redundant monitor mode,
- 3 =dual-redundant controller mode.

The operating mode is determined by a combination of hardware and software settings. See Chapter 2 for the hardware settings and Section 5.2.1 (p 4-27) in this chapter for the software settings.

## 4.3 EXTENDED ERROR CODES

The extended error codes stored in RAM location --105<sub>H</sub> consist of the same error codes that appear in the Interface Control Register, and some extra ones. The error codes and their meanings are:

- 0 =No error.
- 1 =Dual port RAM error.
- 2 =Local RAM error.
- 3 =Boot code ROM error.
- 4 =Main code ROM error.
- 5 =Firmware failure. (Watchdog has reset the '4B Interface.)
- 6 =Host software failure. See Section 5.3 for further information.
- 7 =Not applicable.
- 8 =Programming: Bad S-record - does not start with 'S'.
- 9 =Programming: Bad S-record checksum.
- 10 =Programming: ROM (IC ) failed to program.
- 11 =Programming: ROM (IC ) failed to program.
- 12 =Programming: S-record data was not word aligned.

RAM location --105<sub>H</sub> and the Interface Control Register are located in different areas of hardware. This allows a fault in one area to be reported in the other: for example, a RAM error may make RAM location --105<sub>H</sub> inaccessible, but the relevant error code could still be read from the Interface Control Register.

## 4.4 SOFTWARE STATUS AND ISSUE

RAM locations --110<sub>H</sub> and --111<sub>H</sub> hold the status and issue of the Boot software currently installed in the Interface. Similarly, RAM locations --112<sub>H</sub> and --113<sub>H</sub> hold the status and issue of the Main software. Should new software be installed then the status and issue are updated automatically.

## 4.5 FLASH CHECKSUM

The Flash Checksum Registers allow the Host PC to check the correct loading of the Interface software. Locations --121<sub>H</sub> through --128<sub>H</sub> hold the even and odd checksums for Sectors 0 and 1, as shown in Table 4.4. Locations --129<sub>H</sub> through --140<sub>H</sub> are reserved for the checksums of Flash Sectors 2 through 7, which are assigned in the same way.

**Table 4.4 Flash Checksum Registers**

RAM Location	Checksum
---121 <sub>H</sub>	Flash Sector 0: even checksum (m.s.)
---122 <sub>H</sub>	Flash Sector 0: even checksum (l.s.)
---123 <sub>H</sub>	Flash Sector 0: odd checksum (m.s.)
---124 <sub>H</sub>	Flash Sector 0: odd checksum (l.s.)
---125 <sub>H</sub>	Flash Sector 1: even checksum (m.s.)
---126 <sub>H</sub>	Flash Sector 1: even checksum (l.s.)
---127 <sub>H</sub>	Flash Sector 1: odd checksum (m.s.)
---128 <sub>H</sub>	Flash Sector 1: odd checksum (l.s.)

Location --120<sub>H</sub> holds the flash checksum summary. Bits 0 and 1 in this location indicate the checksum status for Sectors 0 and 1: '1' = checksum O.K.; '0' = checksum error. Bits 2 through 7 are reserved for the checksum summaries of Flash Sectors 2 through 7.

## 4.6 REAL-TIME CALENDAR AND CLOCK

The '4B Interface maintains a real-time Calendar and Clock (Figure 4.4) for timing the IMP functions.

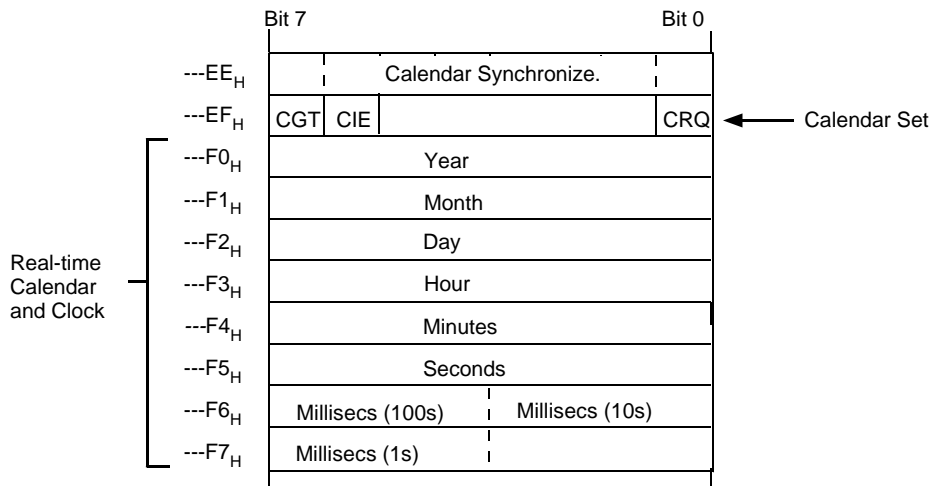

**Figure 4.4 Real-time calendar and clock.**



The Calendar and Clock are set by the Host PC and can be left to run at an accuracy determined by the Interface on-card crystal (error less than 2.5 seconds a day). Alternatively, it is possible to synchronize the Interface clock to the system clock. Access to the Calendar and Clock is requested by the Host PC, and granted by the Interface, through the Calendar Set Register. The Calendar and Clock are set by writing an eight-byte time value into locations ---F0<sub>H</sub> through ---F7<sub>H</sub>. Each byte is expressed in binary-coded decimal format. Synchronization to the system clock is maintained through the Calendar Synchronize Register.

When the Interface is reset, the Calendar and Clock are disabled and the real-time registers are cleared to zero. The Calendar and Clock should then be set up, as described in Section 4.6.3. When this has been done the Interface automatically broadcasts the time to all IMPs every second. IMPs with time-related facilities may store this time and use it to perform IMP functions. All IMPs are thus synchronized to the time that the Host PC writes to the Interface.

*It is not intended, as part of the normal operation of the '4B, that the calendar and clock should be read. Due to the fact that the clock and calendar are maintained, it is possible that the clock will be read half updated and so give the 'wrong' time. If, to avoid this, you use the CRQ/CGT bits to freeze the calendar and clock, the settings when you release the calendar and clock will be taken as the updated settings, thus causing the '4B to lose time: this is equivalent to halting the clock for the time it is under user control.*

#### 4.6.1 Synchronizing the Clock

If software synchronization is to be used for the real-time clock, the byte at location ---EE<sub>H</sub> should be set non-zero on a second boundary. The Interface clears this byte ready for the next second synchronization.

#### 4.6.2 Accessing the Calendar

Access to the real-time calendar by the Host PC is requested and granted through the Calendar Set Register, at location ---EF<sub>H</sub>. The bit functions of this register are as follows:

- CGT Bit 7: Calendar Grant. The '1' state indicates to the Host PC that access to the Calendar is granted.
- CIE Bit 6: Calendar Interrupt Enable. When set to '1' causes the Host PC to be interrupted when Calendar access is granted.
- CRQ Bit 0: Calendar Request. When set to '1' requests access to the Calendar by the Host PC.

### 4.6.3 Setting Up the Calendar and Clock

To set up the real-time calendar and clock go on as follows:

1. Request access to the calendar and clock by setting the Calendar Request bit (CRQ) in the Calendar Set byte, also setting the Interrupt Enable bit (CIE) if an interrupt is required when access is granted.
2. Wait for either the Calendar Grant bit (CGT) to be set, or for the interrupt which indicates that this has happened.
3. Write the current operating system time into the calendar registers.
4. Clear the Calendar Set byte to release access to the calendar.

Once initialized, the calendar and clock can be left to run free at an accuracy determined by the on-board crystal (error  $<2.5\text{s/day}$ ). Alternatively, to synchronize the clock to the operating system clock, a non-zero value should be written to the Calendar Synchronize byte at the "roll-over" of each second. Note that it is essential to keep the interval between each write to the Calendar Synchronize byte as close to one second as possible, so that the phase-locking process can maintain a regular real-time clock.

## 4.7 SELECTING IMPS FOR POLLING

By setting the appropriate bits in the The Poll Table (Figure 4.5) the Host PC tells the Interface which IMPs are to be polled for data. Throughout the table each bit represents a specific IMP. Going from bit 0 in location ---C8<sub>H</sub> through to bit 1 on location ---CE<sub>H</sub> the IMPs represented are IMP 1 through IMP 50.

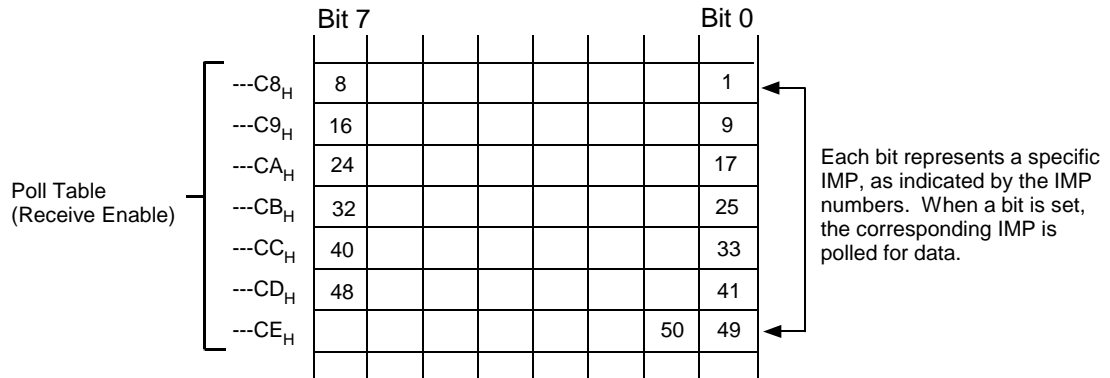

**Figure 4.5 Poll table.**

In general, a bit should be set for each IMP from which measurement data is required. (See note on power up settling delay below.) Immediately the poll bits are set by the Host PC the Interface begins to poll the corresponding IMPs, checking for data and reporting any communication errors detected.

The poll table setup can be altered at will without reinitialising the interface, but, once set, a bit should not be cleared unless communication errors occur, due for example to IMP removal or 'not present'.

### **NOTE: Power Up Settling Delay**

After power has been applied to the S-Net, the IMPs take time to become fully operational. For 50V at the IMP, this time could be up to 1 second, whereas for 10V, it is up to 3 seconds. The voltages quoted are those actually at the IMP, not those applied to the S-Net at the Controller. The times quoted apply to IMPs *other than* UIMPs: for UIMPs the times should be doubled.

Setting poll bits before the power up time has elapsed can result in poll errors being generated. Therefore it is necessary to delay setting up the poll table by a time slightly in excess of the power up time.

## 4.8 SELECTING THE RAM PAGES

The Page Select Register, at location ---FF<sub>H</sub>, allows the Host PC to select any other RAM page from Page 0. When the number of the required page is written into this register the Interface moves the RAM window to allow access to this page. A Page Select Register on the selected page, when read, returns the RAM window to Page 0. See Section 2.1 on page 4-5.

## 4.9 TRANSMITTING DATA TO THE IMPS

The Transmit Registers (Figure 4.6) allow the Host PC to communicate with the Interface when it wishes to transmit data to the IMPs. The data to be transmitted is written by the Host PC into RAM Page 1. The function of each Transmit Register is described in Sections 4.9.1 through 4.9.5 below.

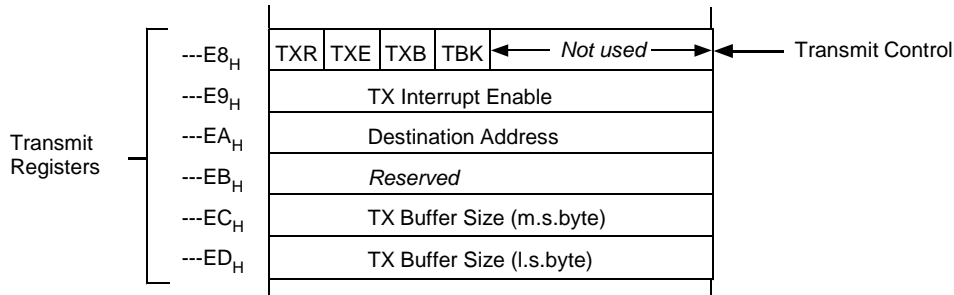

**Figure 4.6 Transmit registers.**

### 4.9.1 Transmission Control

The Transmit Control Register is used to control and give status information of transmissions by the Interface. The bit functions are as follows:

**TXR** Transmit Request. The Host PC sets the TXR bit to tell the host Interface that the data on RAM Page 1 is to be transmitted. Another transmit can be requested only when the TXB bit is cleared by the Interface.

On transmission complete the TXR bit is cleared. (This is a more precise indication of transmission complete than the clearance of the TXB bit.)

**TXE** Transmit Error Flag. The Interface sets the TXE bit to indicate a transmission error.

**TXB** Transmit Busy. The Interface sets the TXB bit to indicate that transmission has started. The bit is cleared after transmission ends; another transmit can then be requested.

**TBK** Transmit Break. The Host PC sets this bit to tell the Interface to transmit a break character on the S-Net.

The break character resets all IMPs on the network. It is primarily intended for resetting locally powered IMPs, although it can be used both for locally powered IMPs and for those that are powered remotely through S-Net. An indication that all IMPs are reset is given by the bit state returning to '0'. A break character can be used to re-establish correct system operation in the event of transmit or receive errors.

**Transmit or receive errors may be caused by the practice of removing an IMP, or replacing one, in an operational system. Although this practice is sometimes expedient, and certainly will not damage the IMP hardware, it can cause errors and is not recommended.**

### 4.9.2 Transmission Interrupts

An interrupt is generated if the byte at location ---E9<sub>H</sub> is non-zero and TXR in the Transmit Register is clear.

### 4.9.3 Destination Addressing

The Destination Address Register, in location ---EA<sub>H</sub>, holds the address of the IMP that is to receive the data on RAM page 1. The destination address is written into this register by the Host PC.

A message may be 'broadcast' to all IMPs on the system by making the destination address zero. This facility is intended primarily as means of synchronizing the time between the '4B Interface and the IMPs attached to it on S-Net: time data is sent to all IMPs simultaneously, so that they can operate in a common time frame. Other messages, such as a measure command, may also be broadcast, which gives a marginal increase in data throughput. With a broadcast message, however, message reception goes unchecked, and no indication is given to the Host PC that a message has been received or not. Therefore, it is not recommended that broadcast messages are used in a secure environment, i.e. one in which the function of every IMP is critical and where the failure of any IMP to respond to a command must be reported to the Host PC.<sup>1</sup>

### 4.9.4 Transmit Buffer Size

Two bytes are used to hold the number of bytes that are to be transmitted. The maximum number is 256, which is the maximum capacity of the transmit buffer on RAM Page 1.

### 4.9.5 Transmit Sequence

To transmit a message to an IMP the Host PC must take the following steps:

1. Write the message onto RAM Page 1, starting at address ----0<sub>H</sub>.
2. On RAM Page 0, set up the Transmit Registers as follows:
  - a. Specify the number of bytes to be transmitted by writing this into the Tx Buffer Size register.
  - b. Specify the IMP that is to receive the command by writing its address into the Destination Address Register.
  - c. Initiate the transmission by setting the TXR (Transmit Request) bit in the Transmit Register.
  - d. If a transmit complete interrupt is required, set the Tx Interrupt Enable byte to non-zero.

<sup>1</sup>In the case of time broadcasts, acknowledgment of reception is of no consequence. The time is broadcast at regular intervals and any IMP not receiving the time, due to being busy, should receive the time data on the next broadcast, or the next, or the next..... Any total failure of an IMP to receive data will, of course, be reported to the Host when that IMP is polled after the transmission of a normal message.

When the Transmit Request has been recognized the Interface sets the Transmit Busy bit (TXB) and the message is transmitted on the S-Net. If the message is sent to a specific IMP, i.e. the Destination Address is not zero, the IMP is polled immediately after the message has been sent, in order to verify correct reception. If an acknowledgment of the message is not received, up to three re-tries are performed before an error is reported to the user.

When transmission is complete the Interface sets the bits in the Transmit Control Register as follows:

- Transmit Request (TXR) - clear.
- Transmit Error (TXE) - set only if transmission has failed.
- Transmit Busy (TXB) - clear.

If the Interrupt Enable byte was set the Interface generates a 'transmission complete' interrupt.

#### 4.10 READING THE RECEIVED DATA STATUS

The receive table has the format shown in Figure 4.7. Four consecutive bytes are assigned to each IMP, and these contain the receive status for Data Streams 0 through 3. For each IMP and data stream the table tells the Host PC whether the data transmitted by an IMP is ready in the Interface RAM, or whether the Interface has failed to receive this data. Each receive status byte also contains an address offset: this tells the Host PC where to start reading the data stream on the relevant page of RAM.

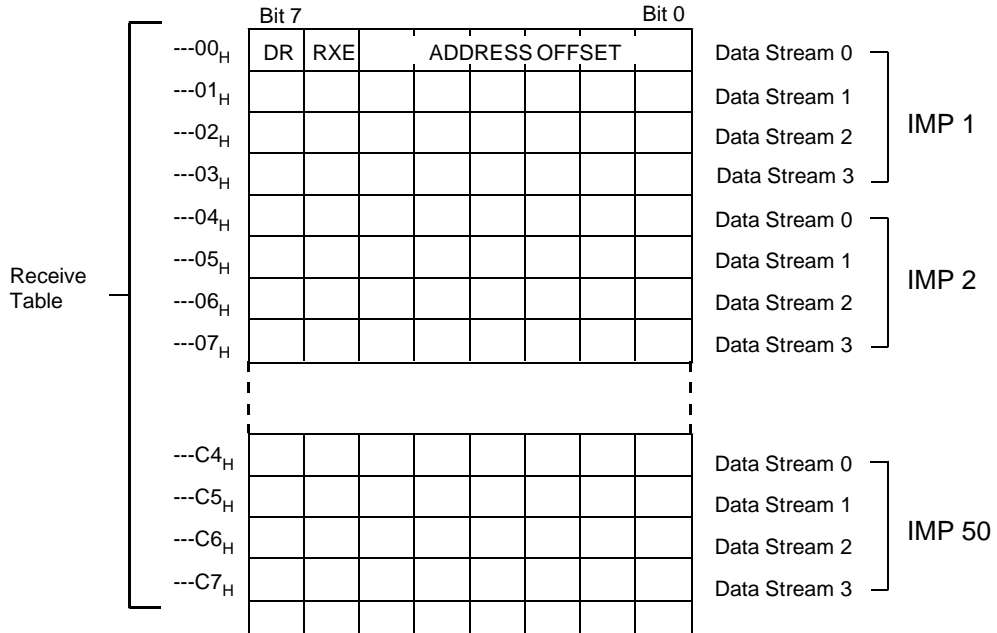

**Figure 4.7 Receive table.**

For each receive status byte, the bit functions are:

- DR Data Ready. When set, this bit indicates that some new data has been received and is ready on the RAM page assigned to storing the IMP measurement results.
- RXE Receive Data Error. When set, this bit indicates that the Interface has failed after three attempts to receive the data transmitted by an IMP.
- Address Offset Bits 0 through 5 contain a RAM location address offset (divided by 4). This points to the location in RAM where the first byte of the data stream is located. All data starts on long word boundaries (four bytes).

(The measurement results received from IMPs 1 through 50 are stored on RAM Pages 2 through 51.)

### 4.11 SETTING RECEIVE INTERRUPTS

The Receive Interrupt Table (Figure 4.8) is intended for use in task programming. It allows the Host PC, by setting the relevant bits, to select the data streams for which it is to be interrupted on completion of a receive operation.

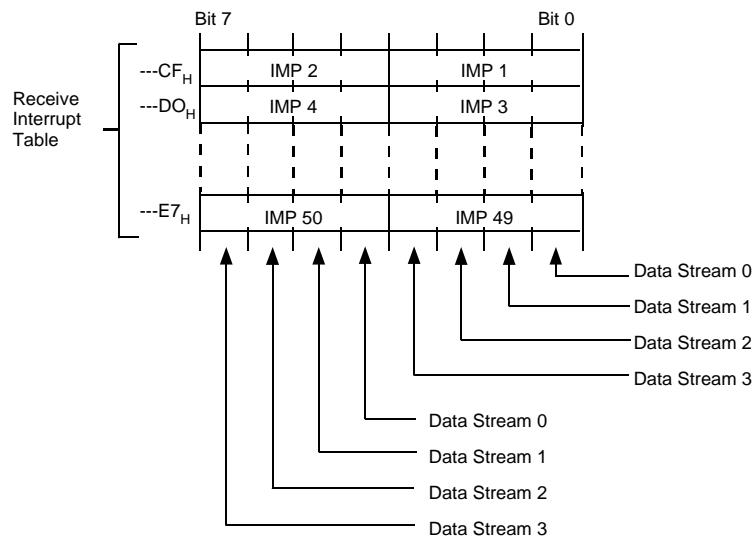
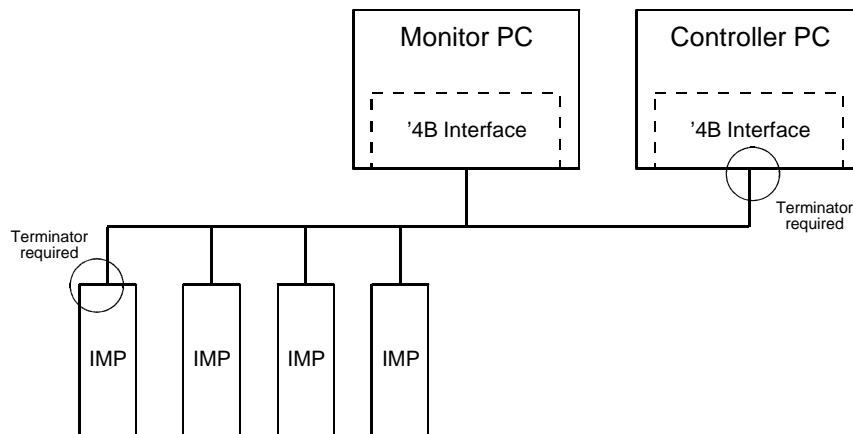

**Figure 4.8 Receive interrupt table.**

Each of the four-bit bytes into which the table is divided is assigned to a specific IMP and, within each byte, each bit is assigned to a specific data stream. When the Host PC sets a bit in this table the Interface generates an interrupt either when measurement data is ready in the Interface RAM, or when the Interface has failed to receive measurement data. An indication of either occurrence is given by the Data Ready and Receive Data Error bits in the relevant byte of the Receive Table (see Section 4.10 on page 4-22).

## 5 DUAL REDUNDANCY CONTROL

In a dual redundancy system two '4B Interfaces are connected to the same S-Net. One Interface controls S-Net in the usual way. The second Interface, by detecting 'polls' on the S-Net, monitors the behavior of the first. The presence of polls indicates that the control Interface is operating correctly: the absence of polls indicates that it isn't. In the second case the monitor Interface provides status information that tells the monitor PC to take over S-Net control. A typical dual-redundancy system is shown in Figure 4.9.



**Figure 4.9 Typical dual-redundancy system.**

It is emphasised that the only thing a monitor Interface does is to check for the presence of polls on S-Net. Whilst polling continues, the monitor Interface does nothing else. Should polling stop, however, then the monitor Interface sets the Poll Fail Interrupt Request Enable (PRQ) bit in its Dual Redundancy Control (DRC) register. It is then the responsibility of the Monitor PC software to take the appropriate action. Normally this would be to assume S-Net control by setting the relevant bits in the DRC register. (See Sections 5.2.1 and 5.2.2.)

Note that for the Monitor PC to take over S-Net control it must contain control software. This can be done, for example, by running a copy of the control software used by the control PC, stored ready for use in the Monitor PC memory. Alternatively, the software could be downloaded from a central source.

Note that when the Control PC comes back on line it must take back control only when no other '4B has control of S-Net. For this reason the startup sequence of the Control PC and Monitor PC needs careful consideration.

In a dual redundancy system both '4B Interfaces must be set for dual redundancy operation. This is done with a hardware switch setting, as described in Chapter 2. (Chapter 2 also describes the S-Net connections and terminations for dual-redundancy operation.) All other setups, and dual redundancy control, are managed by the PC software, which operates through the Dual Redundancy Control (DRC) register. The bit functions of this register are summarized in Section 5.1, and the general programming details are described in Section 5.2.



## 5.1 DUAL REDUNDANCY CONTROL REGISTER

The Dual Redundancy Control (DRC) register provides the following dual control functions:

- ‘Poll failed’ indication, for use by a monitor program.
- ‘Reset occurred’ indication.
- Echo facility, which can be used by the Host PC to check the operation of the Interface software and hardware.
- Poll fail interrupt enable, for use by a monitor Interface.
- S-Net transmit enable, for use by a control Interface.
- Watchdog enable, for use by both the controller and monitor Interface. When enabled the watchdog monitors the continued operation of the PC program: the program must continually ‘pat’ the watchdog by accessing the DRC register, otherwise the Interface suspends its operation.

The DRC register (Figure 4.10) appears on two RAM pages, Page 0 and Page 255. On both pages the register is located at address --102<sub>H</sub>. On RAM Page 0 of the register all bits are read only: on RAM Page 255 all bits are both read and write.

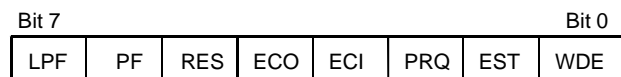

**Figure 4.10 Dual Redundancy Control Register**

The bit functions of the DRC Register are:

- WDE** Watchdog Enable. When set, enables the Host software watchdog. The Host PC must then ‘pat’ the watchdog periodically, by toggling the ECI bit. (The WDE bit can be cleared only by resetting the Interface. (That is, by toggling the RST bit in the IC register).)
- EST** Enable S-Net Transmit. When set, this bit enables all transmissions from the Interface to S-Net. The EST bit is set in a ‘controller’ Interface, but not in a ‘monitor’ Interface. (**NOTE:** The state of the EST bit should only be changed whilst the ‘4B Interface is held in reset. That is, whilst bit 6 (RST) in the Interface Control Register is in the ‘0’ state. See Section 5.2.1.)
- PRQ** Poll Fail Interrupt Request Enable. Enables an interrupt if poll fail is detected by the Interface. This bit is used by a ‘monitor’ Interface: it is ignored if the EST (Enable S-Net Transmit) bit is set (as in a ‘control’ Interface).
- ECI** Echo In. This bit may be used, in conjunction with the ECO bit, to check that the Interface software and hardware are still operational. The Host PC toggles the ECI bit and, if the Interface is operational, the ECO bit assumes

the complement of this setting within 36ms. (Toggling this bit also clears the RES and LPF bits.)

ECO	Echo Out. <i>See description of ECO bit above.</i>
RES	Reset Occurred. If, after being set, this bit is subsequently found to be reset it is an indication that the Interface has been reset, either by the watchdog or by a power failure. (The RES bit is cleared by the ECI bit.)
PF	Poll Fail. When set to '1' in a 'monitor' Interface indicates that the Interface is unable to detect any polls on the S-Net. Has no meaning when the EST (Enable S-Net Transmit) bit is set (as in a 'control' Interface).
LPF	Latched Poll Fail. This is a latched copy of the PF bit. (The LPF bit is cleared by the ECI bit.)

## 5.2 DUAL REDUNDANCY PROGRAMMING

This section describes the actions that must be taken by the 'control' program and the 'monitor' program in a dual-redundancy system.

Initially, the control program sets the '4B Interface in the control PC to operate in control mode and the monitor program sets the '4B Interface in the monitor PC to operate in the monitor mode. (See Section 5.2.1.) Thereafter the control PC remains in control of S-Net until an error or ISA reset occurs. During this time the control and monitor PCs can check the operation of their respective '4B Interfaces by reading the Dual Redundancy Control (DRC) register. (Section 5.3 describes the various failure detection facilities made available through the DRC register.)

Should the control PC fail then S-Net polling stops. This is detected by the '4B Interface in the monitor PC and the monitor program should then be able to take over S-Net control. To enable this to happen the monitor program should have access to the same setup data as the control program.

**Note:** Before a dual-redundancy system can be programmed, the hardware of both the '4B Interfaces involved must be set for dual-redundancy operation: see Chapter 2 for details.

## 5.2.1 System Initialization

The operation of a '4B Interface as a 'controller' or a 'monitor' is set by the EST (Enable S-Net Transmit) bit in the DRC register. After an ISA reset the EST bit is set to '0': this ensures that each Interface in a dual redundancy system starts off as a 'monitor' on power up.

To avoid errors the EST bit should be set whilst the '4B Interface is held in reset from the Interface Control (IC) register. The following pseudo-code describes this.

### Initialization of '4B Interface to monitor mode:

```
Select page ---FF
Clear location --100      (ICR)   reset Interface
Clear location --102      (DRC)   clear S-Net transmit enable
Set bit 6 in location --100 (ICR)   release Interface reset
Select page 0
Delay for 1000ms          to allow the '4B software to start
```

### Initialization of '4B Interface to controller mode:

```
Select page ---FF
Clear location --100      (ICR)   reset Interface
Clear location --102      (DRC)   clear all DR bits
Set bit 1 in location --102 (DRC)   select S-Net transmit enable
Set bit 6 in location --100 (ICR)   release Interface reset
Select page 0
Delay for 1000ms          to allow the '4B software to start
```

## 5.2.2 Switching from Monitor to Controller Mode

When S-Net activity stops the Monitor PC program must use the following procedure to switch the monitoring '4B to the control mode.

1. Select RAM page 255.
2. Reset the '4B.
3. Clear all bits in the DRC then set the EST bit.
4. Release the '4B from reset.
5. Select RAM page 0.
6. Wait 1s.
7. Set the Calendar and Clock. (This causes all the IMPs to receive a new time, which relates to the (new) controlling PC.)
8. Set the Poll Table bits to receive data on the required streams.

## 5.3 FAILURE DETECTION

When operated in a dual redundancy system the '4B Interface has several features that enable a fault to be detected. These are:

1. Should an Interface be reset by a hardware reset signal on the ISA bus (for example, following a brief power failure) it reverts to monitor mode. [**The control Interface stops polling S-Net.**]
2. Should an Interface be reset by its internal firmware watchdog it places error code '5' in the error registers and sets the RES (reset occurred) bit in the DRC register. [**The control Interface stops polling S-Net.**] The firmware will not restart until the Interface is reset by toggling the RST bit in the DRC register.
3. The ECI (echo in) and ECO (echo out) bits allow the PC software to check that the firmware of an Interface is operating correctly. A '1' written into the ECI bit starts a sequence that results in a '0' being written into the ECO bit. When the '0' appears within 36ms it may be assumed that the firmware is OK. The Host PC may use this feature as a confidence check. (This check is additional to the one provided by the firmware watchdog.)
4. A software watchdog may be used to verify the correct operation of the software in either a controller or a monitor PC. The software watchdog is enabled by writing a '1' into the WDE (watchdog enable) bit of the DRC register. The WDE bit may be set at any time, but it can be cleared only by resetting the Interface. (That is, by toggling the RST bit in the IC register).

Once the WDE bit is set the software must toggle the ECI bit at least once every 10 seconds. Otherwise, the watchdog assumes that the software has failed and stores error code '6' in the error registers. [**The control Interface stops polling S-Net.**] In the latter case the firmware will not restart until the RST (reset) bit is toggled in the IC register.

5. Should the **monitor Interface** detect the **absence of polls** on S-Net it sets the PF (Poll Fail) and LPF (Latched Poll Fail) bits in the DRC register. The PF bit reflects the current state of S-Net and therefore clears itself should polling continue. The LPF bit remains set, however, until the ECI bit is toggled. (Toggling the ECI bit clears both the LPF and the PF bit.)

If required, an interrupt can be generated when the PF bit is set. An interrupt is enabled by setting the PRQ (Power fail interrupt ReQuest enable) bit in the DRC register. The interrupt is cleared when either the PF bit is cleared or the PRQ bit is cleared.

Various failure scenarios and suggested recovery strategies are outlined in Section 5.4.

## 5.4 FAILURE RECOVERY

Possible failures and the relevant recovery procedures in a dual redundancy system are outlined in Table 4.5.

**Table 4.5 Failure Recovery Strategies for Dual Redundancy Systems**

Failure	Recovery Strategy
Control PC fails. No power to Interface.	Having no power, the control Interface stops polling. This is detected by the monitor Interface and a poll fail is indicated to the monitor PC program. This program must then take over active control of the system and make the monitor Interface into the control Interface.
Control PC fails. Power to Interface.	The control Interface continues to poll for a short period, until the control software watchdog is triggered by the failure of the PC program to 'pat' it. The control Interface then indicates an error and suspends S-Net operations. This results in a poll fail being detected by the monitor Interface and indicated to the monitor PC program. The monitor program must then take over active control of the system and make the monitor Interface into the control Interface.
Control Interface fails.	The control Interface stops polling. This is detected by the monitor Interface and a poll fail is indicated to the monitor PC program. This program must then take over active control of the system and make the monitor Interface into the control Interface.
Monitor PC fails. No Power to Interface.	This has no immediate effect on measurements made by the system. However, provision must be made for recognising that the monitor PC is inoperative and repairing it.
Monitor PC fails. Power to Interface.	Same as above.
Monitor Interface fails.	The monitor Interface firmware fails to pat the watchdog and consequently the monitor Interface resets itself. The monitor PC is able to detect the failure by using the Echo Out and Echo In bits in the Dual Redundancy Control Register, or by checking the error register.

## 6 RECEIVING IMP RESULTS AND RESPONSES

---

**Measurement results** from the IMPs are received on RAM Pages 2 through 51, which are assigned to IMPs 1 through 50. Each of these pages contains the data shown in Table 4.6. These various types of data are described in Sections 6.1 through 6.4.

**Table 4.6 Content of RAM Pages 2 through 51**

<b>Location Addresses* (hex)</b>	<b>Function</b>
000 - 04F (r/w)	Data stream 0 (80 bytes)
070 - 073 (r/w)	Data stream 1 (4 bytes)
080 - 0EF (r/w)	Data stream 2 (112 bytes)
0F0 - 0FB (r/w)	Data stream 3 (12 bytes)
0FC - 0FF (r)	Unallocated
0FF (w)	Page address
100 - 101 (r/w)	Stream 0 size
102 - 103 (r/w)	Stream 1 size
104 - 105 (r/w)	Stream 2 size
106 - 107 (r/w)	Stream 3 size
108 - 109 (r/w)	Stream 0 time tag
110 - 117 (r/w)	Stream 1 time tag
118 - 11F (r/w)	Stream 2 time tag
120 - 127 (r/w)	Stream 3 time tag
128 (r/w)	Unallocated
129 (r/w)	Transmit retry count
12A - 1FF (r/w)	Unallocated

## 6.1 DATA STREAMS

IMPs are able to return four types of data, each type having its own format. To allow the application program to categorize and attach different priorities to the data types the S-Net protocol segregates them into four data streams. The data to stream assignments are listed in Table 4.7, together with the size of the buffers that accommodate them.

**Table 4.7 Data to Stream Assignments**

Stream No.	Data Conveyed	Buffer Size
0	Measurement scan, or long numeric response.	80 bytes
1	Single channel measurement, or short numeric response.	4 bytes
2	Event information (35952A and 35952B only).	112 bytes
3	Command responses, in ASCII.	12 bytes

**NOTE:** In response to an SA command (SAve setup data - see Chapter 1, in Part 2 of the manual) more than 80 bytes may be sent in Stream 0 by an IMP. This may overwrite the boundaries of the area reserved for Stream 0, in the Interface input buffer space. Stream 0 for the 3595 2B switch pod is 128bytes wide. (Therefore this pod does not use Stream 1.)

## 6.2 STREAM SIZE

The size (number of bytes) of each data stream, that is the number of bytes it contains, is stored in locations ---100<sub>H</sub> through ---107<sub>H</sub>. See Figure 4.11.

---100 <sub>H</sub>	Stream 0 size (most sig. byte)
---101 <sub>H</sub>	Stream 0 size (least sig. byte)
---102 <sub>H</sub>	Stream 1 size (most sig. byte)
---103 <sub>H</sub>	Stream 1 size (least sig. byte)
---104 <sub>H</sub>	Stream 2 size (most sig. byte)
---105 <sub>H</sub>	Stream 2 size (least sig. byte)
---106 <sub>H</sub>	Stream 3 size (most sig. byte)
---107 <sub>H</sub>	Stream 3 size (least sig. byte)

**Figure 4.11 Stream size locations.**

### 6.3 STREAM TIME TAGS

A time tag is stored for each stream of data received. This includes the date and the time at which the reception of data at the '4B Interface was completed. For the location of the various date and time elements see Figure 4.12.

Stream Number:					
0	1	2	3		
---108 <sub>H</sub>	---110 <sub>H</sub>	---118 <sub>H</sub>	---120 <sub>H</sub>	Year	
---109 <sub>H</sub>	---111 <sub>H</sub>	---119 <sub>H</sub>	---121 <sub>H</sub>	Month	
---10A <sub>H</sub>	---112 <sub>H</sub>	---11A <sub>H</sub>	---122 <sub>H</sub>	Day	
---10B <sub>H</sub>	---113 <sub>H</sub>	---11B <sub>H</sub>	---123 <sub>H</sub>	Hour	
---10C <sub>H</sub>	---114 <sub>H</sub>	---11C <sub>H</sub>	---124 <sub>H</sub>	Minute	
---10D <sub>H</sub>	---115 <sub>H</sub>	---11D <sub>H</sub>	---125 <sub>H</sub>	Second	
---10E <sub>H</sub>	---116 <sub>H</sub>	---11E <sub>H</sub>	---126 <sub>H</sub>	millisecs (100s)	millisecs (10s)
---10F <sub>H</sub>	---117 <sub>H</sub>	---11F <sub>H</sub>	---127 <sub>H</sub>	millisecs (1s)	

**Figure 4.12 Stream time tag locations.**

### 6.4 TRANSMIT RETRY COUNT

The transmit retry count (stored in location ---129<sub>H</sub>) indicates the quality of transmission on S-Net, from the Interface to the IMPs.

For each character that the Interface transmits to an IMP it expects a response: this is part of the S-Net protocol. Should an IMP fail to respond, three retries are made before an error is reported. Where the quality of transmission is marginal then transmission may, in many cases, succeed after several attempts, and errors will not be reported. This is where the transmit retry count can provide a useful check.

Retries should be kept to a minimum, since they increase the time taken to transmit data streams. Where the retry count is particularly high then the serviceability of equipment on S-Net should be investigated.



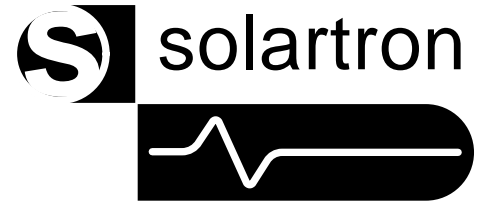

## ***Part 2***

# IMP Commands and Responses



# *Operator Manual: Part Two*

## *IMP Commands and Result Formats*

### **Chapter 1      IMP Commands**

- 1      Introduction
- 2      Command Summary
- 3      Command Directory
- 4      Suggested Command Procedures

### **Chapter 2      Result and Error Formats**

- 1      Introduction
- 2      IEEE 754 Floating Point Format
- 3      Four-Byte Result Format
- 4      Event result Format
- 5      Time Tag Formats ('1H and '1J IMPs)
- 6      Historical Data Formats ('1H and '1J IMPs)
- 7      IMP Error Messages

### **Appendix A      Database Structure ('1H and '1J IMPs)**



# IMP Commands

## Contents

<b>1</b>	<b>Introduction</b> .....	1-3
1.1	Command Strings .....	1-3
1.2	IMP Command Types .....	1-3
1.3	Numbers in Commands .....	1-3
1.4	Examples of Command Strings.....	1-4
1.5	Incorrect Commands.....	1-5
1.6	Command Delays.....	1-5
<b>2</b>	<b>Command Summary</b> .....	1-6
<b>3</b>	<b>Command Directory</b> .....	1-8
3.1	Commands for Analog And Digital Measurements .....	1-9
3.2	Commands for Analog Measurements Only .....	1-30
3.3	Commands for Thermocouple Measurements .....	1-34
3.4	Commands for Strain Gauge Measurements.....	1-36
3.5	Commands for Digital Measurements Only .....	1-38
3.6	Commands for Analog Outputs .....	1-43
3.7	Additional Commands for Universal IMPs '1H and '1J.....	1-48
<b>4</b>	<b>Suggested Command Procedures</b> .....	1-57

### List of Figures

Figure 1.1	Scan synchronization of '1H and '1J IMPs.....	1-25
Figure 1.2	Connections to 3595 3Y calibration connector block.....	1-45

## List of Tables

Table 1.1	IMP Command Summary .....	1-6
Table 1.2	Additional Commands for '1H and '1J IMPs .....	1-7
Table 1.3	Mode Codes for IMPs Type '1A, '1C and '1E .....	1-10
Table 1.4	Mode Codes for IMP '1B (Strain). .....	1-11
Table 1.5	Mode Codes for IMP Type '2A (Digital). .....	1-12
Table 1.6	Mode Codes for IMP Type '2B (Switch IMP) .....	1-13
Table 1.7	Mode Codes for IMPs Type '1H and '1J.....	1-14
Table 1.8	Database Bytes ('1A, '1B, '1C, '1E, '2A and '2B IMPs) .....	1-22
Table 1.9	Database Bytes ('1H and '1J IMPs) .....	1-22
Table 1.10	Average Scan Times for Fast Integration IMPs. ....	1-24
Table 1.11	IMP Codes. ....	1-27
Table 1.12	Connector Block Codes. ....	1-28
Table 1.13	Scan Rates v Integration Times for Totally Fast IMP System. ....	1-31
Table 1.14	Scan Rate (scan/sec) v No. of Fast IMPs for Five-IMP System. ....	1-32
Table 1.15	Sample Rate Settings. ....	1-38
Table 1.16	Default Sample Rates. ....	1-38
Table 1.17	Time-out Periods. ....	1-39
Table 1.18	Calibration Responses.....	1-44
Table 1.19	Analog Output Status Codes. ....	1-47

# 1 INTRODUCTION

---

This chapter provides information on the use of IMP commands, a summary of commands, a detailed command directory, and suggested command procedures.

**NOTE:** Details of the Vibration IMP (VIMP) commands are given in the SI3595 1F&G VIMP Programmer's Manual (Part No. 35952200).

## 1.1 COMMAND STRINGS

The following rules apply to command strings:

- a. They must not contain more than 256 characters (bytes).
- b. They may contain any number of individual commands as long as they are separated by semi-colons. Commands are executed in order, left-to-right across the string, and responses are returned in this order.
- c. They must not contain unnecessary spaces, or lower case characters.
- d. If a command includes some binary information, all bytes of this data must be included. Its omission can cause both the command involved and any subsequent commands in the string to be misinterpreted.

## 1.2 IMP COMMAND TYPES

Command strings are built from two basic command types:

General Commands - applicable to most IMPs.

Specific Commands - applicable only to a particular type of IMP. For example, the EV command applies only to the digital and switch IMPs.

**Note:** IMP addressing is dealt with in Part 1 of this manual.

## 1.3 NUMBERS IN COMMANDS

The majority of commands require one or more numbers to further specify the command. For example, the **ME** (measure) command, must be specified with a channel number. Unless otherwise noted in the command directory, these numbers are ASCII (keyboard) characters and not numeric variables. For example: **ME1**.

## 1.4 EXAMPLES OF COMMAND STRINGS

A string of two or more commands may be sent by inserting semi-colons between individual commands. On receipt of a command string the IMP executes each command in turn, in the order in which it appears in the string. Each command string should not exceed 256 characters in length, including semi-colons.

As an example, the command sequence **SE;TR** provides a quick measurement setup:

1. On IMPs *other than* the universal IMPs '1H and '1J it selects 'volts dc autoranging' for analog measurement IMPs and 'digital status' for the digital and switch IMPs. On the universal IMPs it sets analog channels 1 through 18 to 'volts dc autoranging' and digital channels 19 and 20 to 'digital status'.
2. It arms the IMP(s) to make measurements.
3. It tells the IMP(s) to take a scan – that is, measure on all channels.

Other useful command sequences are:

- a. **RE;CH $n$ MO103;ME $n$**  (For analog measurement IMPs and universal IMPs)  
This command resets previous settings, sets channel  $n$  to 'volts dc 2V range', and tells the IMP to take a measurement on channel  $n$ . (On IMPs *other than* universal IMPs channel  $n$  can be any channel: on universal IMPs channel  $n$  can be any channel from 1 through 18.)

- b. **RE;CH $n$ MO902;ME $n$**  (For digital IMPs and universal IMPs)

This command resets previous settings, sets channel  $n$  to 'frequency measurement – gate time 1 second', and then tells the IMP to take a measurement on channel  $n$ . (On IMPs *other than* universal IMPs channel  $n$  can be any channel: on universal IMPs channel  $n$  can be either channel 19 or channel 20.)

- c. **SE ; CO ; TR** (For any measurement IMP(s))  
This command sets all IMPs (all channels) to either 'volts dc autoranging' (analog measurement IMPs) or digital status (digital and switch IMPs) and enables measurements, enables continuous measurement scanning, and then starts the scanning (measuring on all channels). Scans will continue being made until the buffers available are full or until the **HA** (HAIt) command is transmitted.
- d. Examples a. and b. above can be extended to setting up every channel on an IMP and then taking a scan. To do this, use the **CH MO** entry in the Command Directory to decide the required function of each channel. Then string together all the appropriate **CH MO** commands (one for each channel). As an example, an IMP type 1A would have twenty **CH MO** commands sent to it in order to configure every channel, i.e.

**RE ; CH1MO100 ; CH2MO500 ;.....; CH20MO310 ; AR ; TR**

- e. **RE ; CH1MO600 ; CH1GAN $n_1n_2n_3n_4$  ; IN1 ; ME1** (For analog IMPs type 1B only)

where  $n_1 \dots n_4$  = IEEE 754 floating-point number  
 $n_1$  = most significant byte

For a strain gauge factor of, say, 2.25,



first byte	$n_1 = 01000000_2$ equivalent to $64_{10}$
second byte	$n_2 = 00010000_2$ equivalent to $16_{10}$
third byte	$n_3 = 00000000_2$ equivalent to 0
fourth byte	$n_4 = 00000000_2$ equivalent to 0

This command sequence resets previous settings, sets channel 1 to measure strain using a ½-bridge (4mA) configuration on autoranging, uses a strain gauge factor of 2.25 in strain calculations, initializes the strain gauge, and then tells the IMP to take a measurement on Channel 1.

A detailed explanation of how to convert the decimal number '2.25' into a binary number in IEEE 754 floating-point format, as used in the **CHannel GAuge** command shown above, is given in Chapter 2, Section 2.

## 1.5 INCORRECT COMMANDS

The IMP checks command strings for correct syntax. If it finds a command that it does not understand, it ignores the command and moves on to the set of characters after the next semi-colon (or the next command string if the message ends before a semi-colon occurs). For example, if the following command string is sent to an IMP:

**HELLO; TR**

The first five characters **HELLO** mean nothing to the IMP and it will ignore these. The command **TR** will then be acted on.

However, it is possible to send an IMP a command that it understands, *but can't obey*. The command may, for example, specify an invalid mode or range. In such a case the IMP stores an appropriate error code and returns this when it next receives a measure or trigger command for the affected channel(s). Thus, when the command string does not instruct an immediate response, the error is not immediately reported, which may lead to some confusion.

Therefore it is important that the application program checks that each command sent is of the correct syntax, and that the command parameters are valid.

## 1.6 COMMAND DELAYS

To ensure that an IMP correctly executes commands it is good practice to insert a delay of 100ms between command strings and 500ms after each of the following commands: REset, TRigger, and HAlt.

## 2 COMMAND SUMMARY

Table 1.1 IMP Command Summary

Com'nd	Applicable to ...									Purpose	Ref. Sect.
	'1A	'1B	'1C	'1D	'1E	'1H	'1J	'2A	'2B		
AR	*	*	*		*	*	*	*	*	Arms IMPs.	3.1
CH MO	*	*	*		*	*	*	*	*	Sets channel mode.	"
CO	*	*	*		*	*	*	*	*	Continuously scans channels.	"
DI	*	*	*		*	*	*	*	*	Cancels the ARm command.	"
HA	*	*	*		*	*	*	*	*	Halts all measurements.	"
LO	*	*	*		*	*	*	*	*	Loads SAvEd set-up information.	"
ME	*	*	*		*	*	*	*	*	Takes a single measurement	"
RE	*	*	*	*	*	*	*	*	*	Sets all IMP settings to the defaults.	"
SA	*	*	*		*	*	*	*	*	Store set-up data.	"
SE	*	*	*		*	*	*	*	*	Quick set-up of all IMPs.	"
SP	*	*	*		*	*	*	*	*	Sets the scan period.	"
ST	*	*	*	*	*	*	*	*	*	Requests information on IMP type.	"
TR	*	*	*		*	*	*	*	*	Requests an ARmed IMP to read data.	"
CA	*	*	*		*	*	*			Calibration on specific ranges.	3.2
DR	*	*	*		*	*	*			For test purposes only.	"
FR	*	*	*		*	*	*			Sets the integration time.	"
KA	*	*	*	*	*	*	*			Calibrate ON.	"
UN	*	*	*		*	*	*			Selects units of Temperature.	"
AM	*		*		*	*	*			Ambient temperature reference.	3.3
TE	*		*		*	*	*			Sets reference temperature.	"
TC	*		*		*	*	*			Sets thermocouple check for open-circuit.	"
CH GA		*								Loads IMP with gauge factor.	3.4
CH OF		*								Sets the strain gauge offset.	"
IN		*								Sets strain gauge parameters.	"
CH RA						*	*	*		Sets the sample rate.	3.5
CH TI						*	*	*		Sets the time-out period.	"
CL						*	*	*		Clear event totalize counter.	"
EV								*	*	Enables event capture.	"
ES								*	*	Event status.	"
HW						*	*		*	Enable/Disable Hardware watchdog.	"
SF									*	Status Format, IEEE 754 or compressed.	"
SW						*	*		*	Enable/Disable Software watchdog.	"
CH VO				*						Sets channel to voltage.	3.6
CH IO				*						Sets channel to current.	"
CH CV				*						Calibrates voltage channel.	"
CH CI				*						Calibrates current channel.	"
OS				*						Requests information on output chans.	"

**Table 1.2 Additional Commands for '1H and '1J IMPs**

<b>Command</b>	<b>Purpose</b>
CH LR	Returns the loop resistance of a thermocouple.
CH UC	Converts a measured parameter into alternative units, with the function $y=mx+c$ .
UT	Defines a set of coefficients to be used for thermocouple linearisation. (These are applied by selecting the appropriate channel mode.)
CH PL	Enables a measured parameter to be linearised into alternative units.
PL	Defines the coefficients of the polynomial applied by CH PL.
CH HL	Defines the high limit for channel alarm checking.
CH LL	Defines the low limit for channel alarm checking.
CH GO	Defines the group of alarm channels to be used with a digital output channel.
AS	Enables an IMP to start automatically after a hard reset.
RM	Selects the result mode from: real-time, time tagged, historical.
FB	Flushes the historical results buffer.
SD	Saves the data base in the IMP flash PROM.
RD	Restores the data base in the flash PROM to the data base proper.

### 3 COMMAND DIRECTORY

---

In this directory the IMP commands are classified under the following headings:

- Section 3.1** Commands for Analog and Digital Measurements. (p1-9)
- Section 3.2** Commands for Analog Measurements Only. (p1-30)
- Section 3.3** Commands for Thermocouple Measurements. (p1-34)
- Section 3.4** Commands for Strain Gauge Measurements. (p1-36)
- Section 3.5** Commands for Digital Measurements Only. (p1-38)
- Section 3.6** Commands for Analog Outputs. (p1-43)
- Section 3.7** Additional Commands for Universal IMPs. (p1-48)

In each section the commands appear in alphabetical order.

Each command description is headed with the command code, and the command title in brackets, for example

**CH MO**<sub>(set CHannel MOde)</sub>

The command syntax is shown by a flow diagram, which includes any command variables, for example

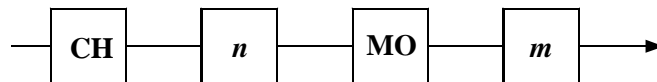

*n* is an integer which defines the channel number:

- in the range  $1 \leq n \leq 20$  for IMPs type '1A, '1C, '1E, '1H, '1J, and '2A,
- in the range  $1 \leq n \leq 10$  for IMPs type '1B and
- in the range  $1 \leq n \leq 32$  for IMPs type '2B

*m* is a 3-digit code which defines the channel mode (see Tables 1.3 through 1.7).

Note that command codes are shown in upper case characters and variables in lower case. Only the items in boxes form part of the command string. A description of each command variable, and its limits, appears under the flow diagram, as shown above. Following the flow diagram the following information is given:

- Note** Detailing specific IMPs when appropriate.
- Function** Description of command function.
- Response** What the IMP transmits to the host in response to the command.
- See also** Other related commands.

In some cases an example of use is given also.

## AR (ARm)

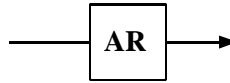

- Note** This command does not apply to analog output IMPs (type '1D).
- Function** Arms IMP(s). Only an armed IMP can respond to a command to scan all channels (**TRigger**). This allows individual IMPs to be armed; only these IMPs will then respond to a broadcast **TRigger**. Once an IMP is armed it will continue to respond to **TRigger** command until **DI**sarmed.
- Response** None.
- See also** TR, DI
- 

## CH MO (set CHannel MOde)

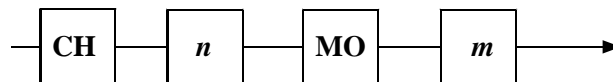

*n* is an integer which defines the channel number:  
 in the range  $1 \leq n \leq 20$  for IMPs type '1A, '1C, '1E, '1H, '1J, and '2A,  
 in the range  $1 \leq n \leq 10$  for IMPs type '1B and  
 in the range  $1 \leq n \leq 32$  for IMPs type '2B .

*m* is a 3-digit code which defines the channel mode (see Tables 1.3 through 1.7).

- Note** This command does not apply to analog output IMPs (type '1D).
- Function** Sets channel mode (measurement function and range) on specified channel. See Tables 1.3 through 1.7 for encoding details.
- Response** None. If an IMP is given a channel mode command with which it is unable to comply, it will return the error message 'unknown mode, type or range', but only when it is instructed to measure.

Any channel can be set to skip. The channel is then not measured and returns the error message 'not measured' in place of any data requested. Channels set to 'skip' can be left unterminated. Channels set to a particular mode (other than skip), but not used, should be shorted-out at the connector block.

**Table 1.3 Mode Codes for IMPs Type '1A, '1C and '1E**

Code, m	Mode Set		Comments
000	skip		
100	Volts, dc,	autoranging.	The 10V range overranges to 12V.
101	"	20mV range.	
102	"	200mV range.	
103	"	2V range.	
104	"	10V range.	
310-314	Thermocouple	type E.	The third digit sets the range: 0=autoranging, 4=least sensitive range (10V).  *Type B and N thermocouples may be used only with IMPs marked with product status C3 onwards.
320-324	"	type J.	
330-334	"	type K.	
340-344	"	type R.	
350-354	"	type S.	
360-364	"	type T.	
370-374	"	type B*.	
380-384	"	type N*.	
500	Current, dc,	autoranging.	Channels used for current measurements require the fitting of a 100Ω shunt. (see IMP Installation Guide.)
501	"	200μA.	
502	"	2mA.	
503	"	20mA.	
504	"	100mA.	

**Note:** By using an HV connector block (type '3D) the 10V range can be converted into a 250V range. If the HA (attenuated) input is used, results returned by the IMP must be multiplied by 50.

**Example** The command **CH1MO330** configures channel 1 of an addressed IMP type '1A or '1C to measure K type thermocouples.

**Table 1.4 Mode Codes for IMP '1B (Strain).**

Code, m	Mode Set	Comments
000	skip	
100	Volts, dc, autoranging.	Note that there is no 10V range on IMP type '1B.
101	" 20mV range.	
102	" 200mV range.	
103	" 2V range.	
200	Resistance, 4-terminal, 0.8mA drive, autoranging.	
201	" 25Ω range.	
202	" 250Ω range.	
203	" 2k5Ω range.	
210	Resistance, 3-terminal, 0.8mA drive, autoranging*.	*Only those IMPs with product status C6 onwards are able to comply with an autoranging command.
211	" 25Ω range.	
212	" 250Ω range.	
213	" 2k5Ω range.	
400	RTD/PRT, 100Ω, 4-terminal, " autoranging.	
401	" 20mV range.	
402	" 200mV range.	
403	" 2V range.	
410	RTD/PRT, 100Ω, 3-terminal, " autoranging*.	*Only those IMPs with product status C6 onwards are able to comply with an autoranging command.
411	" 20mV range.	
412	" 200mV range.	
413	" 2V range.	
600-603	Strain Gauges: 1/2-bridge, 4mA dual current.	The last digit in the code sets the range: 0=autoranging, 1=20mV range, 2=200mV range, 3=2V range.
610-613	" 0.8mA dual current.	
620-623	1/4-bridge, 4mA dual current.	
630-633	" 0.8mA dual current.	
640-643	Full-bridge, 8mA drive.	
650-653	" 1.6mA drive.	
660-663	Three-wire, 4mA drive.	
670-673	" 0.8mA drive.	

**Table 1.5 Mode Codes for IMP Type '2A (Digital).**

Code, m	Mode Set	Comments
000	skip	
700	Digital status	
740 741 742	Event count totalize: -ve going edge +ve going edge +ve or -ve going edge	On receipt of a measurement trigger, keeps a continuous count of events. This count may be cleared either by the CL command or by setting the channel mode again to event count totalize.
750 751 752	Event count increment: -ve going edge +ve going edge +ve or -ve going edge	A continuous count of events is kept, since the last trigger. On receipt of the next trigger the event count is stopped, the result is sent to the host, and another event count is begun.
760 761 762	Event capture: -ve going edge +ve going edge +ve or -ve going edge	Enabled by EV command only.
800 801	Switch output off (high) Switch output on (low)	For digital output, sets channel to logic '1' or '0'.
900 901 902 903	Frequency Measurement: gate time = 10ms. " = 100ms. " = 1s. " = 10s.	
910 911 912 913	Multiple periods: 1 period. 10 periods. 100 periods. 1000 periods.	Returns the time over which the number of periods are counted. Measurement starts on the negative-going edge.
920 921	'One-shot' time: -ve going start, +ve going stop. +ve going start, -ve going stop.	Measures -ve pulse width. Measures +ve pulse width.

**Note:** -ve edge refers to a negative-going edge, a transition from high to low.  
+ve edge refers to a positive-going edge, a transition from low to high.

**Event Count** This facility permits a number of events to be counted. The events (transitions) to be included in the count can be +ve, -ve, or both. Two types of count are offered: *increment* or *totalize*. These operate as follows:

*Increment* On receipt of a measurement trigger, an event count is started. Then, on receipt of another measurement trigger, the event count is stopped, the result sent to the host interface, and another count begun.

*Totalize* On receipt of a measurement trigger, events are counted until an HA (halt) command is received or until the channel mode is set to event count increment. In the latter case the counter is cleared, prior to starting the



incremental count. If a CL (clear) command is received at any time, the event counter is reset to zero and a new count started on receipt of the next measurement trigger. The event counter of a particular channel is also cleared when that channel is set again to the event totalise mode.

The maximum number of events that can be recorded, per channel, by the event counting circuitry is 16,777,215, after which the count continues from zero. No other indication of this is given.

**Table 1.6 Mode Codes for IMP Type '2B (Switch IMP)**

Code, m	Mode Set	Comments
000	skip	
700	Digital status	
760 761 762	Event capture: -ve going edge +ve going edge +ve or -ve going edge	Enabled by EV command only.
800 801	Switch output off (high) Switch output on (low)	For digital output, sets channel to logic '1' or '0'.

**Note:** -ve edge refers to a negative-going edge, a transition from high to low  
+ve edge refers to a positive-going edge, a transition from low to high.

Channels 29 to 32 are digital input / output channels. Digital outputs are set when the IMPs receive the relevant **CHMO** command. For more details on each individual mode, refer to the IMP Installation Guide.

**Table 1.7 Mode Codes for IMPs Type '1H and '1J**

Code, m	Mode Set	Comments
000	skip	
100	Volts, dc, autoranging.	Same modes as for 1A, 1C and 1E.
101	" 20mV range.	
102	" 200mV range.	
103	" 2V range.	
104	" 10V range.	
		The 10V range overranges to 12V.
200	800/80µA drive, autoranging.	Four-wire resistance ranges. 🖱
201	800µA drive, 25Ω range.	
202	800µA drive, 250Ω range.	
203	800µA drive, 2k5Ω range.	
204	80µA drive, 25kΩ range.	
210	800/80µA drive, autoranging.	Three-wire resistance ranges. 🖱
211	Not used	
212	Not used	
213	800µA drive, 1k5Ω range.	
214	80µA drive, 25kΩ range.	
220	800/80µA drive, autoranging.	Two-wire resistance ranges.
221	Not used	
222	Not used	
223	800µA drive, 500Ω range.	
224	80µA drive, 25kΩ range.	
310-314	Thermocouple type E.	Same modes as for 1A, 1C and 1E.
320-324	" type J.	
330-334	" type K.	
340-344	" type R.	
350-354	" type S.	
360-364	" type T.	
370-374	" type B.	
380-384	" type N.	
390-394	" User TC 1	
3A0-3A4	" User TC 2	
		The third digit sets the range: 0=autoranging, 4=least sensitive range (10V).
		User defined linearization. (See UT description in Section 3.7.2)
400	800µA drive, autoranging.	Four-wire, 100Ω, RTD/PRT ranges. 🖱
401	800µA drive, -200°C to -180°C	
402	800µA drive, -200°C to +400°C	
403	800µA drive, -200°C to +600°C	
410	800µA drive, autoranging*.	Three-wire, 100Ω, RTD/PRT range. 🖱 (One useful range.)
411	<i>Do not use.</i>	
412	<i>Do not use.</i>	
413	800µA drive, -200°C to +600°C	
		*Autoranges to code 413 range.
420	800µA drive, autoranging*.	Four-wire, 10Ω, RTD/PRT range. 🖱 (One useful range.)
421	800µA drive, -200°C to -180°C	
422	<i>Do not use.</i>	
423	<i>Do not use.</i>	
		*Autoranges to code 421 range.
430	800µA drive, autoranging*.	Three-wire, 10Ω, RTD/PRT range. 🖱 (Not recommended.)
431	<i>Do not use.</i>	
432	<i>Do not use.</i>	
433	800µA drive, -100°C to +150°C	
		*Autoranges to code 433 range.

🖱 Three- and four-wire resistance and temperature measurements use a pair of channels (connected as shown in Chapter 12 of the 3595 Series IMP Installation Guide). The channel mode is configured for the odd numbered channel (e.g. Channel 1). Any configuration set up for the companion even numbered channel (e.g. Channel 2) is ignored, but, for good practice, it is recommended that this channel is configured for 'skip' (code 000).

Code, m	Mode Set	Comments
500 501 502 503 504	Current, dc, autoranging. " 200 $\mu$ A. " 2mA. " 20mA. " 100mA.	Channels used for current measurements require the fitting of a 100 $\Omega$ shunt. (See IMP Installation Guide.) (Same modes as for '1A, '1C and '1E.)
700 701 702	TTL logic levels. 12V (3V/9V) logic levels. Two-wire, 25k $\Omega$ measurement.	Digital status inputs. Codes 701 and 702 apply only to channels 1 through 18. 1 = high (V or $\Omega$ ) measured. 0 = low (V or $\Omega$ ) measured.  (For channels 19 and 20 the only logic level mode applicable is mode 700. Selection of the TTL or 12V logic levels is made by split pads in the connector block.)
710 720	Reserved for internal use. Reserved for internal use.	
740 741 742	-ve going edge +ve going edge +ve or -ve going edge	Event count totalize. A continuous count of events is kept, reset only by the CL command. (Same modes as for '2A.)
750 751 752	-ve going edge +ve going edge +ve or -ve going edge	Event count increment. A continuous count of events is kept, since the last trigger. (Same modes as for '2A.)
800 801	Switch output off (high) Switch output on (low)	For digital output, sets channel to logic '1' or '0'. Similar modes to '2A, <i>but</i> : (a) Status of channel can be read back, (b) Outputs default to Off on power-up.
900 901 902 903	Gate time = 10ms. " = 100ms. " = 1s. " = 10s.	Frequency Measurement.
910 911 912 913	1 period. 10 periods. 100 periods. 1000 periods.	Multiple period measurement. Returns the time for one period, in seconds. (Same modes as for '2A.)

For status measurements on channels 1 through 18 the logic levels applicable are:

Mode 700 (TTL)	$m < 0.8V$	= '0';	$m > 2.4V$	= '1'
Mode 701 (3V/9V)	$m < 3V$	= '0';	$m > 9V$	= '1'
Mode 702 (25k $\Omega$ )	$m < 100\Omega$	= '0';	$m > 1k\Omega$	= '1'

In each of the above modes the last value measured is maintained during the intermediate region (for example, in Mode 700, where  $0.8V < m < 2.4V$ ).

For frequency and period measurements on channels 19 and 20 (modes 900 - 903 and 910 - 913) the following conditions apply:

**For continuous scans** a '1H or '1J IMP does not wait for a measurement to complete, but returns the error code 0xFF8D (*measurement pending*) for all scans until a result is available. When the measurement is complete, the result is returned in the next scan.

**For a single scan** the results are not returned until the measurement is complete.

**EXAMPLE:**

1. Assume that the measured input is a 20Hz (nom.) square wave, and that mode 902 has been selected. This means that the frequency of the square wave is to be measured for 1s (the 'gate' time).

For continuous scanning, with a scan period of 100ms, error code FF8D is returned in place of each of the first nine results. On the tenth scan a valid measurement result ( $\approx 20\text{Hz}$ ) is returned. This sequence is repeated whilst continuous scanning is in operation.

For a single scan the result ( $\approx 20\text{Hz}$ ) is returned on completion of the 1s gate time.

2. Assume that the measured input is a 200 Hz (nom.) square wave, and that mode 901 has been selected. This means that the frequency of the square wave is to be measured for 100ms.

For continuous scanning, with a scan period of 100ms, a valid measurement result ( $\approx 200\text{Hz}$ ) is returned for each scan.

For continuous scanning, with a scan period of 1s, a valid measurement result of the same accuracy is returned every 1s.

For a single scan the result ( $\approx 200\text{Hz}$ ) is returned on completion of the 100ms gate time.

---

---

## CO (COntinuous measurement)

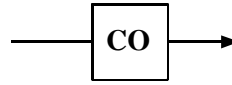

**Note** This command does not apply to analog output IMPs (type '1D').

**Function** Instructs an **AR**med IMP, upon receiving **TR**igger, to continuously scan all channels and return data.

An IMP can hold the measurement results of two complete scans in a pair of output buffers. When continuous measurement starts, the IMP puts the results of the first scan in the first buffer then the results of the second scan in the second buffer. If the scan period is set to 0ms (default value) and the host is able to read the results of the first scan by the time the second scan is complete then a third scan is started when the second scan is finished, and the results placed in the first buffer. This sequence continues and allows the IMP to continuously scan its inputs, without waiting for scan data to be read by the host. If the scan period is defined the start points of successive scans are separated by this period. Also, if the host is unable to read the scan data as fast as the IMP provides it then the IMP 'hangs' whilst the host catches up.

Note that universal IMPs type '1H' and '1J' do not 'hang' in the historical mode, but continue scanning even when the output buffer is full. This is to allow the alarm inputs to continue to be monitored. Until the host reads data from the buffer the data presently stored is not overwritten and the most recent results are discarded.

For more information on buffering refer to Part 1 of the manual.

**Response** As **TR**igger, subsequent scans are loaded into the IMP output buffer as previous scans are accepted by the host computer.

**See also** TR, AR, SP, RM

---

## DI (DIsarm)



**Note** This command does not apply to analog output IMPs (type '1D').

**Function** Cancels the **AR**m command.

**Response** None.

**See also** AR

---

## HA (HAIt)

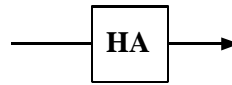

**Note** This command does not apply to analog output IMPs (type '1D).

**Function** Cancels the continuous measurement mode. Should an IMP be making measurements when the **HAIt** command is received then, before halting, it completes the scan and sends the results to the host. If no measurements are being made, however, the IMP halts immediately.

The **HAIt** command does not alter the scan period (set with the SP command).

**Response** Stream 3. Single character H

This response confirms that measurement has stopped.

---

## LO (LOad set-up data to IMP)

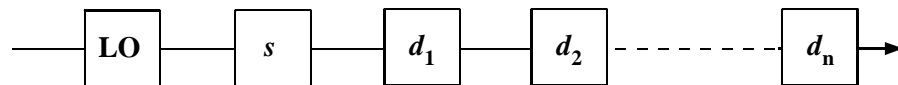

*s* is the database:

1, 2 or 3 for IMPs type '1A, '1B, '1C, '1E, '2A and '2B and  
1, 2, 3.....7 for the universal IMPs type '1H and '1J.

$d_1$ -----  $d_n$  are *n* data bytes, where *n* is dependent on the IMP type and on the database.

**Note** This command does not apply to analog output IMPs (type '1D).

**Function** Loads previously **SA**ved set-up information into the database of the IMP. This allows the same channel configurations and values to be used after an IMP is powered-down.

**Response** None.

**See also** SA and (for the '1H and '1J IMPs) SD and RD.

---

---

## ME (MEasure a channel)

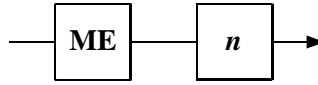

$n$  an integer which defines the channel number:  
in the range  $1 \leq n \leq 20$  for IMPs type '1A', '1C', '1H', '1J' and '2A',  
in the range  $1 \leq n \leq 10$  for IMPs type 1B.

**Note** This command does not apply to IMPs type '1D' or '2B'.

**Functions** Instructs IMP to take a single measurement on a specified channel. On IMPs *other than* '1H' and '1J', the channels set for event capture, skip, or digital output are not affected by this command, but return the error message 'not measured' in place of a result. However, the digital channels (19 and 20) on the '1J' and '1H' IMPs, when set for digital output, respond to an ME command by returning the current status.

MEasure starts the counting on a single channel set to 'event count increment' or 'event count totalize', provided that counting has not already been started. An initial result of zero is then returned. If counting has been started the result returned is the number of events the IMP has recorded on that channel up to that time. MEasure does not reset any counters.

**Response** Stream 1, one 4 byte result.

**See also** RM (For the '1H' and '1J' IMPs.)

---

## RE (REset)

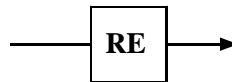

**Function** Sets all IMP settings to their default values - those *normally* assumed on power-up:

- **C**ontinuous 'off'.
- **A**rmed 'off'.
- Defined scan period set to 0ms.
- **K**alibration 'on'.
- **D**rift correct 'on'.
- External temperature 'on'.
- **A**mbient temperature reference 'on'.
- All channels to 'skip'.
- **T**ime-out 2 seconds.
- Temperatures returned in °C.
- Integration time set to 20ms (**FR0**).

*List continued on next page.*

- Voltage and current outputs set to default values (see installation guide).
- Sets scans to be sent over stream 0.
- Sets digital sample rate to default.
- Event counters cleared.
- User conversions cleared and disabled.
- Both user thermocouples cleared.
- Both user post linearisations cleared.
- All channel alarm conditions cleared and disabled.

**Response**    None

---



---

## SA (SAve set-up data)

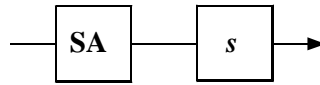

*s* is the database:

1, 2 or 3 for IMPs type '1A, '1B, '1C, '1E, '2A and '2B and  
1, 2, 3.....7 for the universal IMPs type '1H and '1J.

**Note** SA does not apply to analog output IMPs (type '1D).

**Function** On IMPs *other than* '1H and '1J the set-up data (mode, strain gauge data etc.) is stored in one of the three databases in the IMP. Database 1 contains the set-up data selected by the **AR**, **CO**, **UN**, **DR**, **KA**, **AM**, **FR**, and **TE** commands. Database 2 contains the set-up data for individual channels: mode, strain gauge values, etc. Database 3 contains the scan period defined by the **SP** command. (Note that when the scan period is loaded by the **LO** command, with the IMP in continuous scanning mode, the new scan period takes effect from the beginning of the next scan.)

On the '1H and '1J universal IMPs the set-up data is stored in seven databases, as described in Appendix A of Part 2.

**SA** instructs the IMP to transmit this data to the host computer. The complete output buffer capability of the IMP is needed to transmit this data, so the user must ensure that no data is waiting (for transmission) at the IMP. Also, if two **SA**ve commands are sent in quick succession, the IMP may ignore the second one due to shortage of buffer space. This problem can be overcome by putting another command, for example **STATUS**, between the two **SA**ves.

If the IMP is powered-down it loses the contents of its databases. The **LO**ad command, in conjunction with previously **SA**ved data, allows set-up data to be quickly reloaded into the IMP database.

The general procedure for storing and loading an IMP database is:

1. Stop all measurements in progress by the IMP
2. Read all data available.
3. Send an **SA** command.
4. Store the next stream 0 response from the IMP.
5. Repeat steps 3 and 4 for each database to be saved.
6. Power-down and, if required, disconnect the IMP.
7. Power-up and, if required, re-connect the IMP.
8. Send the following string to the IMP: 'L**On**' + bytes originally returned by **SA**n command.
9. Repeat step 8 for each database to be loaded into the IMP.

**Response** Stream 0,  $n$  bytes of data.

**Table 1.8 Database Bytes ('1A, '1B, '1C, '1E, '2A and '2B IMPs)**

IMP type	No. of Bytes in Database 1	No. of Bytes in Database 2	No. of Bytes in Database 3
'1A, '1C & '1E (Thermocouple)	11	63	80
'1B (Strain)	6	163	80
'2A (Digital)	2	100	80
'2B (Switch)	2	97	80

**Table 1.9 Database Bytes ('1H and '1J IMPs)**

IMP type	Number of bytes in Database $D_n$						
	D1	D2	D3	D4	D5	D6	D7
'1H and '1J (Universal)	12	86	165	146	182	180	180

**See also** SD, RD.

---

**SE** (SEt-up to test condition and arm)



**Note** SE does not apply to analog output IMPs (type '1D).

**Function** Quick set-up of most IMPs in the system, for test purposes:

- All analog input channels are set to Volts DC autoranging.
- All digital channels are set to 'digital status'.
- The IMP is armed.

When all channels are set up in this way, unused channels should be shorted-out at the connector block.

**Response** None.

---

## SP (Scan Period)

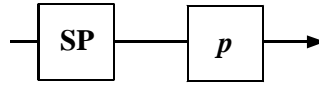

$p$  is a 4-byte floating-point number which defines the scan period, in the range 0ms through 16777215ms.

**Note** This command does not apply to analog output IMPs (type '1D').

**Function** The **SP** command defines the period between the start points of successive scans in the continuous measurement mode and thus allows scan data to be sent to the host at a defined rate.

Defined scan periods are intended to be used with IMPs in the fast scanning mode. (See **FR** command.) For example, a 3595 1A IMP could be set to make a fast scan of 20 thermocouples every second, the duration of each scan being 300ms (FR2):

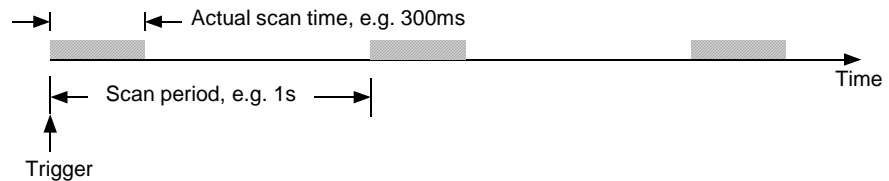

Defining the scan period gives two advantages: (a) it provides a manageable amount of useful data for the host, and (b) the data become available at predictable intervals, thus simplifying the reading of the data.

On power up the scan period is set to the default value of 0ms, which allows the IMP to output scan data at the fastest possible rate. With this, however, the intervals at which the data become available are unpredictable and, if the host is unable to cope with the large amount of data produced, the system may hang. To make the scanned data manageable and predictable the scan period defined by the **SP** command should be at least as long as the actual scan time and should also allow the host time to process each block of scan data as it occurs. As a guide, the average scan times for the various types of IMP and their measurement modes are listed in Table 1.10.

The scan period may be re-defined at any time. If a defined scan period is in operation then a new period effectively merges with the old one. (See note on exception to this, overleaf.) For example, consider a scan with a defined period of five seconds that has been running for one second. Commanding a new scan period of four seconds causes the next scan to start in three seconds.

Conversely, if the new scan period is one second or less then the next scan starts immediately on completion of the present scan. Note that a scan is never terminated by re-definition of the scan period.

**Note:** When a new scan period is loaded with the **LO** command (with continuous scanning) the new period takes effect from the beginning of the next scan.

**Table 1.10 Average Scan Times for Fast Integration IMPs.**

IMP Type	Measurement Mode	Average* Scan Time (ms)			
		FR2	FR3	FR4	FR5
3595 1A	Voltage	189	159	81	71
3595 1B	Voltage	176	155	95	84
3595 1C/1E	Voltage	225	196	112	111
3595 1A	Thermocouple	300	292	270	269
3595 1C/1E	Thermocouple	337	328	311	309
3595 1A	Thermocouple with OCTD	403	385	338	335
3595 1C/1E	Thermocouple with OCTD	474	454	408	408
3595 1B	Strain	360	328	238	221
3595 1B	Resistance	284	254	168	151
3595 1B	Temperature (PRT)	355	322	234	221

An IMP can not be made to output data faster than its inherent measurement rate. If the defined scan period is less than the actual scan time then the IMP outputs the scan data at the maximum, uncontrolled, rate.

The defined scan period is not effective for single scans. With the continuous mode inoperative, scans start immediately on trigger. To ensure long term repeatability of the defined scan period, analog IMPs have their internal calendar clocks synchronized to the time in the host adapter. Synchronization occurs every second. (Due to the uncertainty of the clock in the host/IMP interface, a small number of scans may be lost or gained over a 24 hour period. This number is  $\leq 2500 \div scan\ period$ , where the scan period is in milliseconds.)

**Notes on Autoscan Firmware**

1. IMPs that are not fitted with Autoscan firmware will ignore the SP command.
2. IMPs that have the Autoscan firmware are:
 

3595 1A / 3595 51A	Mod. Strikes	C13/A9
3595 1B / 3595 51B	Mod. Strikes	C17/A10
3595 1C / 3595 51C	Mod. Strikes	C16/A9
3595 2A / 3595 52A	Mod. Strikes	B12/A10
3595 1E / 3595 51E	Mod. Strikes	A1
3595 2B / 3595 52B	Mod. Strikes	A1
3595 1H	Mod. Strikes	A1
3595 1J	Mod. Strikes	A1
4. IMPs that may be fitted, retrospectively, with the Autoscan firmware are:
 

35952A	Mod. Strike	B11, Issue X
359552A	Mod. Strike	A9, Issue X
5. All IMP interfaces must be fitted with the correct issue of firmware - that is, firmware to issue AE. To get the firmware updated for a 3595 4A, 6A or 8A interface, contact your local Solartron Service Center. The '4B and '9A/9B/9D interfaces will always have the correct issue of firmware fitted.

**Example** An example of a command string, in IMPVIEW, using the **SP** command is:

AR;SP'100';CO;TR

Where AR arms the IMP,  
SP'100' sets a scan period of 100ms,  
CO enables the continuous mode and  
TR triggers the IMP.

This command string instructs the IMP to scan continuously, all channels of the IMP, every 100ms.

**Response** None.

**See also** FR, CO, AR, TR.

### SCAN SYNCHRONIZATION OF '1H AND '1J IMPs

To make it possible for scans to be synchronized, the '1H and '1J IMPs are able to delay the start of a scan from the trigger so that, in each IMP, the scan begins on a pre-defined subdivision boundary of a second, minute, or hour. Each IMP has its clock synchronized to that of the Host: therefore, all scans will start at the same point in time. The time subdivisions used for scan synchronization equal the scan period, *where this is an integral submultiple of 1000ms (1s), 60,000ms (1m) or 3,600,000ms (1h)*.

The algorithm that each '1H and '1J IMP uses for scan synchronization operates as shown in Figure 1.1.

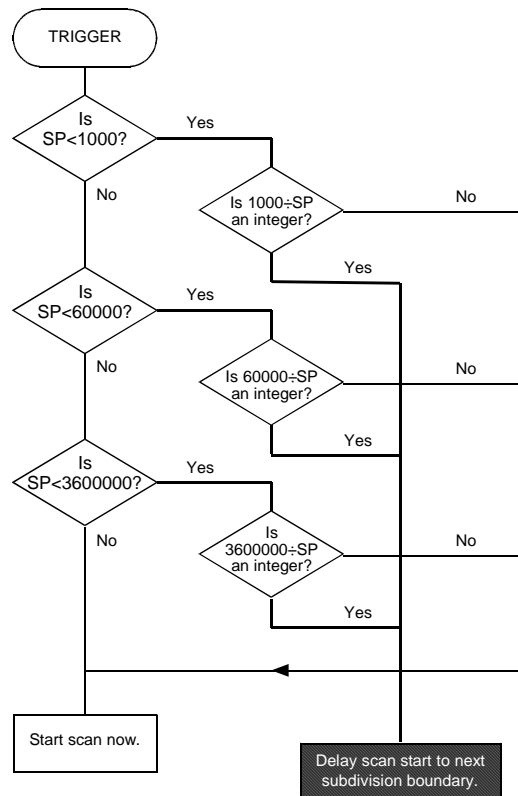
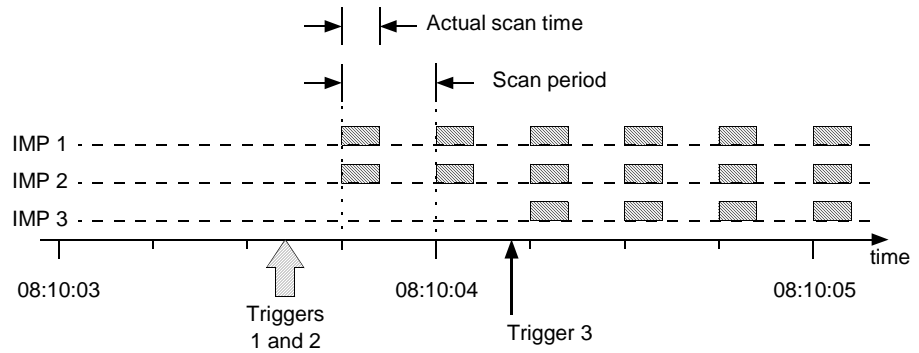

**Figure 1.1** Scan synchronization of '1H and '1J IMPs.

### Example

The command SP '250' is given, which specifies a scan every 250 milliseconds.

$1000 \div 250 = 4$  (remainder 0). Therefore, depending on the time at which the trigger occurs, the scan is delayed until 0ms, 250ms, 500ms, or 750ms past the second:



A scan starts within 50ms (worst case) of the required time.

Only the first scan is aligned. Thereafter, scans are started at the beginning of each scan period –unless the system runs out of output buffers, in which case scan alignment will be lost.

# ST (STatus)



**Function** Instructs IMP to respond with information on type of IMP, connector block and firmware fitted.

**Response** Stream 3, 12 characters:

<i>x</i>	<i>x</i>	<i>b</i>	<i>c</i>		<i>r</i>	<i>f</i>		<i>n</i>	<i>n</i>	<i>y</i>	<i>z</i>
----------	----------	----------	----------	--	----------	----------	--	----------	----------	----------	----------

*xx* IMP code; indicates IMP type, as shown in Table 1.11.

*b* Connector block code; indicates connector block type (see Table 1.12).

*c* Bit function depends on the type of IMP. For the 35951D Analog Output IMP *c* indicates the minimum output current, '0' for 0A or '4' for 4mA. For all other IMPs *c* is set to 'A' if the IMP is capable of responding to an SP command.

*r* binary count of the number of communication retries.

*f* If *f* = F the IMP is capable of responding to an FR0 or FR1 command.

*nnyz* The software number, status and issue. The software numbers are related to the IMP type and are listed in Table 1.11.

**Table 1.11 IMP Codes.**

IMP Code ( <i>xx</i> )	Software No. ( <i>nn</i> )	IMP Type	Standard IMP Part Number
1A	01	Solid State (thermocouple).	3595 1A
1B	02	Strain Gauge.	3595 1B
1C	03	Reed Relay (thermocouple).	3595 1C
1D	11	Analog Output.	3595 1D
1E	25	500V Reed Relay (thermocouple).	3595 1E
1H	30	Universal IMP (200V ch-ch isol.).	3595 1H
1J	30	Universal IMP (500V ch-ch isol.).	3595 1J
2A	04	Digital.	3595 2A
2B	18	Switch.	3595 2B

**Table 1.12 Connector Block Codes.**

Conn. Block Code (b)	Connector Block Type	Connector Block Part Number	
		Standard Block	Glanded Block
A	Thermocouple.	3595 3A	3596 3A
B	Strain Gauge.	3595 3B	3596 3B
C	Digital.	3595 3C	3596 3C
D	Reed Relay Attenuator.	3595 3D	-
E	Analog Output.	3595 3E	-
F	Switch.	3595 3F	-
J	Universal.	3595 3J	-
W	Universal Calibration.	3595 3W	-
Y	Analog Output Calibration.	3595 3Y	-
Z	Calibration.	3595 3Z	-
?	Unknown.	-	-

**Example** A response of 1CDA--F-03FB indicates a 3595 1C reed relay thermocouple IMP with a 3595 3D attenuator connector block and firmware version 03FB. The IMP can respond both to the **SP** command and to the **FR** command.

## TR (TRigger scan)

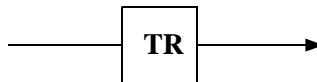

**NOTE:**

1. This command does not apply to analog output IMPs (type '1D).
2. If trigger 'broadcasting' is to be used, please read the relevant sub-section in Chapter 4 of the 3595 4A, 3595 4B, or 3595-9A/9B/9D Operating Manual, before implementation.

**Function** Instructs an **AR**med IMP to make a measurement scan. An IMP must already be **AR**med to respond. If **CO** has already been transmitted, continuous scanning will be started by the **TR** command.

On IMPs *other than* '1H and '1J, the channels set for event capture, skip, or digital output are not affected by this command, but return the error message 'not measured' in place of a result. However, the digital channels (19 and 20) on the '1H and '1J IMPs, when set for digital output, respond to an **ME** command by returning the current status.

**TR**igger will start the counting on all channels set to 'event count increment' or 'event count totalize', provided counting has not already been started. An initial result of zero is then returned. If counting has been started, **TR**igger will return the number of events recorded up to that time; additionally channels set to 'event count increment' will begin counting from zero again.



**Response** Stream 0. Each IMP transmits one 4 byte result for each of its channels. If the status data format command instructs the Switch IMP for compressed data, this data will appear over stream 3 as a 9 byte quantity.

**See also** AR, EV, SF and (for the '1H and '1J IMPs) RM.

---

## 3.2 COMMANDS FOR ANALOG MEASUREMENTS ONLY

---

### CA (CAlibrate)

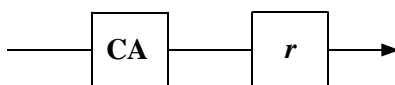

$r$  an integer ( $1 \leq r \leq 8$ ) which defines the analog input range to be calibrated.

**Note** This command does not apply to analog output IMPs (type '1D) or digital IMPs (type '2A and '2B).

**Function** Allows calibration of a specified measurement range on an IMP. Calibration should normally be left to Solartron Instruments service personnel, or to those users with specialist reference equipment.

**Equipment and Procedure** These are detailed in the operating manual entitled 'Calibration of the 3595 Series Analog IMPs' (Part Number 35952233).

---

### DR (DRift correct)

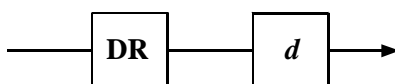

$d = 0$ , continuous update, (default setting)  
 $d = 1$ , fixes drift correct value to existing setting  
 $d = 2$ , sets drift correct value to a nominal test value

**Note** This command does not apply to analog output IMPs (type '1D) or digital IMPs (type '2A and '2B).

**Function** This command is intended for diagnostic and test purposes only. An analog IMP continuously corrects for drift in between measurements. By using the **DR** command the correction may be continuously updated, frozen at the last value or set to a specific test value.

**Response** None.

---

---

## FR (set integration time)

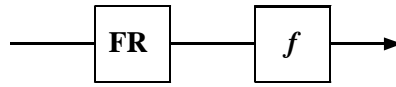

$f=0$	20.00ms	integration time for 50Hz (or 400Hz) supply areas.
$f=1$	16.67ms	integration time for 60Hz supply areas.
$f=2$	5.00ms	integration time for 400Hz supply areas.
$f=3$	4.17ms	integration time.
$f=4$	1.25ms	integration time.
$f=5$	1.04ms	integration time.

**Note** This command does not apply to analog output IMPs (type '1D) or digital IMPs (type '2A and '2B). Further, IMPs type '1A and '1C must have software status 'E' onwards and IMPs type '1B must have software status 'C' onwards to be able to comply with the commands FR2, FR3, FR4, and FR5.

**Function** Sets the integration time of all analog measurements. Provides for optimum rejection of 50Hz, 60Hz or 400Hz supply frequencies. Also allows a shorter integration time to be selected, at the expense of reduced interference rejection, for increased scan rates. (Note: A 'scan' refers to the series of measurements made on all IMP channels and obtained on stream 0.) Typical scan rates (scans per second) obtained with shorter integration times are shown in Table 1.13.

**Table 1.13 Scan Rates v Integration Times for Totally Fast IMP System.**

Integration Time	Scans per Second		
	35951A	35951B	35951C
20ms(FR0)	1.56	2.01	1.48
16.67ms(FR1)	1.88	2.38	1.78
5.00ms(FR2)	5.41	5.85	4.48
4.17ms(FR3)	6.45	6.63	5.16
1.25ms(FR4)	12.95	11.33	9.10
1.04ms(FR5)	14.83	12.50	9.38

The scan rates shown in Table 1.13 are for individual IMPs on a fixed voltage range. (See **SP** command for further information.) Mixing fast and slow IMPs, in a large system, may result in the fast IMPs being slowed down.

Table 1.14 shows the effect on the overall scan rate of increasing the number of fast IMPs (type '1A or '1B) in a five-IMP system. With a small system such as this the fast IMPs are not slowed down by the slow IMPs. Actual throughputs are also dependent on the host computer and the application software.

**Table 1.14 Scan Rate (scan/sec) v No. of Fast IMPs for Five-IMP System.**

No. of Fast IMPs (FR2)	No. of Fast IMPs (FR4)	Combined Scan Rate of Fast IMPs	No. of Slow IMPs (FR0)	Combined Scan Rate of Slow IMPs	Overall Scan Rate
1	-	5	4	4	5+4=9
2	-	10	3	3	10+3=13
3	-	15	2	2	15+2=17
4	-	20	1	1	20+1=21
5	-	25	0	0	25+0=25
-	1	10	4	4	10+4=14
-	2	20	3	3	20+3=23
-	3	30	2	2	30+2=32
-	4	40	1	1	40+1=41
-	5	50	0	0	50+0=50

**Response** Error FF87 'Unknown mode, type or range' is returned, instead of a measurement value, when an unsupported integration time is requested.

**See also** SP

**KA** (calibration on/off)

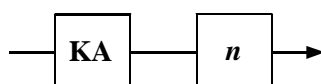

$n = 0$ , calibration on;  $n = 1$ , calibration off

**Note** This command does not apply to digital IMPs (type '2A and '2B).

**Function** With calibration 'on', measurements are corrected with the offset and scale factors kept in EEPROM. These factors are determined during factory calibration, or changed by the calibrate command (CA, CH CV or CH CI), and suit the individual IMP. This function defaults to 'on'.

With calibration 'off', the correction factors used assume perfect components. This provides the user with a reference, or a means to operate with a missing, corrupted, or unprogrammed non-volatile memory.

**Response** None.

**See also** CA, CH CV, CH CI

---

**UN** (UNits of temperature)

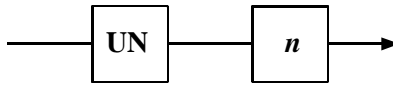

$n = 0$ , IMP communicates in °C  
 $n = 1$ , IMP communicates in °F

**Note** This command does not apply to analog output IMPs (type '1D) or digital IMPs (type '2A and '2B).

**Function** Decides the units of temperature used for:

1. Temperature results (thermocouple and RTD).
2. Setting the external reference temperature with the **TE** command.

The IMPs default to °C (on power-up).

**Response** None.

---

### 3.3 COMMANDS FOR THERMOCOUPLE MEASUREMENTS

---

#### AM (AMbient temperature reference)



**Note** This command applies only to IMPs type '1A, '1C, '1E, '1H, and '1J.

**Function** Instructs IMP to use the ambient temperature as the reference for those channels set for thermocouple measurement. The ambient temperature is sensed by a thermistor in the IMP connector block. This is the default (power-up) condition.

To set an external temperature reference use the **TE** command.

**Response** None.

**See also** TE

---

#### TE (set external TEmpérature reference)

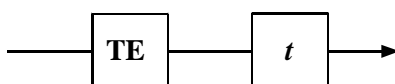

$t$  is the external reference junction temperature, defined by an IEEE 754 floating-point number in the range:

$$-30^{\circ}\text{C}/-22^{\circ}\text{F} \leq t \leq 80^{\circ}\text{C}/177^{\circ}\text{F}.$$

**Note** This command applies only to IMPs type '1A, '1C, '1E, '1H, and '1J.

**Function** Sets the value of the external temperature reference into the IMP. For use only when an external reference<sup>1</sup> junction is to be used. The units used for temperature results and references are set by the **UN** command.

**Response** None.

**See also** AM, UN

---

<sup>1</sup> Historically, called the 'cold' junction –now known, more accurately, as the *reference* junction. Similarly, the 'hot' junction is now known as the *measurement* junction.

---

## TC (set Thermocouple Checking for open circuit)

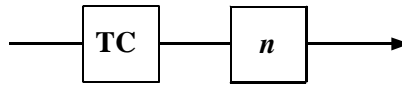

$n=0$ , thermocouple checking off  
 $n=1$ , thermocouple checking on

**Note** This command applies only to IMPs type '1A, '1C, '1E, '1H, and '1J.

**Function** With checking enabled, a second measurement follows the thermocouple measurement: this is to confirm thermocouple integrity. Note that this may slow down the data acquisition rate to less than 1 per second. When an open circuit is detected, the measurement result is replaced with the error code. (Refer to Chapter 2, Section 5.)

**Note:** Only IMPs with a product status marked C8 onwards (and the '1H and '1J universal IMPs) are able to comply with this command.

**Response** None.

---

### 3.4 COMMANDS FOR STRAIN GAUGE MEASUREMENTS

---

#### CH GA (set CHannel GAuge factor)



$n$  is an integer which defines the channel number, in the range  $1 \leq n \leq 10$ ,

$g$  is an IEEE 754 floating-point number defining the strain gauge factor.

**Note** This command applies only to IMPs type '1B with strain gauge(s).

**Function** Loads the IMP database with the gauge factor required for a specified channel. A strain gauge channel cannot perform measurements until it has been **IN**itialized and the gauge factor sent to the IMP.

**Response** None.

**See also** IN, CH OF, LO, SA and Section 1.4 example.

---

#### CH OF (set CHannel OFfset and initial voltage)

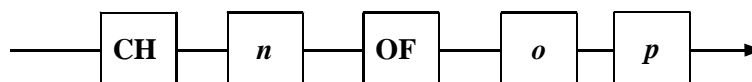

$n$  is an integer which defines the channel number, in the range  $1 \leq n \leq 10$ ,

$o$  an IEEE 754 floating-point number defining the offset in volts,

$p$  an IEEE 754 floating-point number defining the initial gauge voltage.

**Note** This command applies only to IMPs type '1B with strain gauge(s).

**Function** Sets the strain gauge offset and initial voltage values used by an IMP to calculate strain results. These values will have been returned by the **IN**itialize command, and should be stored in the PC. After an IMP has been powered-down, this command can be used to set up a strain gauge channel to the original condition set by the previous **IN** command.

This must be used in conjunction with the **CH GA** command before the strain gauge channel can return data.

**Response** None.

---



---

## IN (INitialize strain gauge parameters)

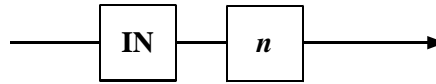

$n$  is an integer which defines the channel number, in the range  $1 \leq n \leq 10$ .

**Note** This command applies only to IMP type '1B with strain gauge(s).

**Function** Before a strain gauge channel can be used the IMP must first know the initial voltage, offset and gauge factor of the strain gauge. These parameters are stored in the IMP's database.

**IN**itialize instructs the IMP to measure the voltage offset and initial voltage of a gauge connected to a specified channel, to store this, and also to transmit this data to the host computer. The IMP must then be informed of the gauge factor using the **CH GA** command. The IMP uses these parameters to calculate strain results, and unless the IMP holds these parameters it will return the error 'strain gauge not initialized' when commanded to measure.

The host computer should be programmed to store the strain gauge data as a string and later (if necessary) send it back to the IMP using the **LO**ad or **CH OF** commands. This allows a re-start after the IMP has been powered down.

**Response** Stream 1,8 bytes,

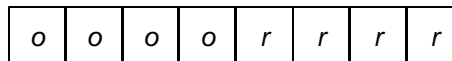

o o o o = out of balance Voltage, represented by 4 bytes

r r r r = initial gauge Voltage, represented by 4 bytes

**See also** CH GA, CH OF, SA, LO

---

## CH RA (set CHannel sample RAte)



$n$  is an integer which defines the channel number, in the range  $1 \leq n \leq 20$ ,

$d$  is an integer which defines the sample rate, in the range  $0 \leq d \leq 4$ .

**Note** This command applies only to IMPs type '1H', '1J' and '2A'. In the case of the '1H' and '1J' IMPs the command applies only to channels 19 and 20.

**Function** Sets the sample rate for the specified channel. The sample rates selectable are listed in Table 1.15.

**Table 1.15 Sample Rate Settings.**

Rate Setting (d)	Sample Rate Selected
0	Default (as on power-up)
1	20Hz
2	1kHz
3	10kHz
4	100kHz

On power-up, the IMP selects the default sample rate. This rate is suited to the mode of operation, as shown in Table 1.16.

**Table 1.16 Default Sample Rates.**

Mode	Default Sample Rate
Digital status.	20Hz
Event counting.	1Hz
Event capture.	1kHz
Frequency.	100kHz
Period.	100kHz
One-shot time.	100kHz

At the sample rates of 20Hz and 1kHz, a level change is detected only if four consecutive samples are the same value. This improves immunity against contact bounce and similar effects. Note, however, that the time recorded for event capture is four sample periods 'late' at the lower sample rates.

**Response** None.

---

---

## CH TI (set CHannel TIme-out)

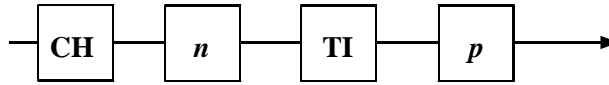

$p$  is an integer which defines the time-out code, in the range  $0 \leq p \leq 5$   
 $n$  is an integer which defines the channel number, in the range  $1 \leq n \leq 20$

**Note** This command applies only to IMPs type '1H, '1J, and '2A.

**Function** For a specific channel, sets the time-out period for period measurement. The settings available are listed in Table 1.17. The default period is 2 seconds ( $p = 1$ ).

**Table 1.17 Time-out Periods.**

Time-out Code (p)	Time-out Period
0	200ms
1	2s
2	20s
3	50s
4	70s*
5	130s*

\*Available on '1H and '1J IMPs only.

The time-out period is the maximum time any period or one-shot measurement is allowed to take. If the period to be measured exceeds this time then the error 'period time-out' is returned in place of a result. For single period measurement of cyclic signals the time-out period must be at least twice that of the measured signal. This ensures that both edges of the signal are within the time-out period.

**Response** None.

---

## CL (CLear event totalize counter)



$n$  is an integer which defines the channel number, in the range  $1 \leq n \leq 20$

**Note** This command applies only to digital IMPs type '2A and universal IMPs type '1H and '1J.

**Function** Instructs the IMP to clear its event totalize counter and to inhibit counting until the next MEasure or TRigger, for a specified channel only. The event totalize counter keeps a continuously updated record of the number of events that have occurred since an initial MEasure or TRigger. It can only be cleared by power-down or the CL command. Maximum count value = 16,777,215.

**Response** None.

---

---

## EV (enable EVent capture)

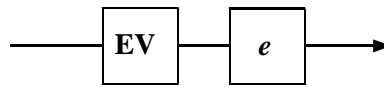

$e = 0$ , stop event capture

$e = 1$ , enable event capture

**Note** This command applies only to digital IMPs type '2A and '2B.

**Function** Enables event capture on any channels in the IMP already set to 'event capture mode'. Event capture can be enabled or stopped only by this command.

**TRigger**, **ARm** or **MEasure** have no effect on event capture.

**Response** Event data is sent in stream 2. For a detailed explanation on event result formats see Chapter 2.

**See also** CH MO, ES

---

## ES (Event Status)



**Note** This command applies only to digital IMPs type '2A and type '2B.

**Function** This command checks the configuration for channels selected for event capture, and for each one, inserts an event status result with time tag into the event buffer. This command operates independently, whether events are enabled or not. If the event buffer is full, this command in part or in full is ignored. It will not affect the events lost count.

**Note:** Only digital IMPs with a product status marked B4 onwards and all switch IMPs are able to comply with this command.

**Response** Event Status data is sent in stream 2. For a detailed explanation on event status formats see Chapter 2.

**See also** CH MO, EV

---

## HW (Hardware Watchdog)

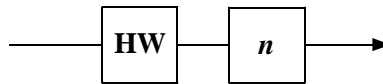

$n = 0$  to disable the watchdog,  
 $n = 1$  to enable the watchdog.

**Note** This command applies only to universal IMPs type '1H and '1J and digital IMPs type '2B.

**Function** Enables or disables the hardware watchdog. Once the watchdog is enabled the watchdog output (channel 20 for the '1H and '1J IMPs, and channel 32 for the '2B) goes from a '0' state to a '1' (no alarm) state. If a time-out period passes without the watchdog being patted the output is set to a '0' (alarm) state, and the IMP is reset into its power up state. The watchdog can then be re-enabled by sending the **HW 1** command. Disabling causes the output to go into its '0' state. Once the watchdog is enabled, power down forces the output into the '0' (alarm) state. The **RE** command does not disable the watchdog.

**Response** None.

---

## SF (Status data Format)

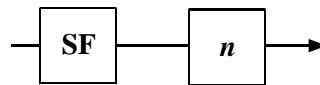

$n = 0$  for IEEE 754 floating-point format  
 $n = 1$  for binary compressed format.

**Note** Applies only to the switch IMPs (type '2B).

**Functions** Command **SF** defines whether scan data is supplied as IEEE 754 floating-point numbers (128 bytes) in stream 0, or as binary compressed quantities (9 bytes) in stream 3, for the single trigger or continuous mode of operation. The default value is IEEE 754 floating-point format.

The binary format consists of :

Byte 1                    ASCII character '%' (37 decimal)

Bytes 2-5                Binary inputs from channels 1 to 32, starting from bit 7 of byte 2 to bit 0 of byte 5 for channels.

Bytes 6-9                Control bytes (one bit per channel). A bit value of '0' indicates that the channel is set to status input. A bit value of '1' indicates the channel is 'Not measured' or 'Unknown Mode, type or range'.

**Response** None.

---

## SW (Software Watchdog)

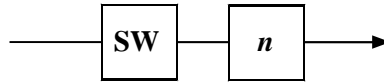

$n = 0$  to disable the software watchdog

$n = 1$  to 255 to set the software watchdog timeout in integer seconds.

**Note** This command applies only to digital IMPs type '2B and universal IMPs type '1H and '1J.

**Function** Enables or disables the software watchdog. Once the watchdog is enabled the watchdog output (channel 20 for the '1H and '1J IMPs, and channel 32 for the '2B) goes from a '0' state to a '1' (no alarm) state. The IMP then expects the **ST** command to be sent within the next 'n' seconds, and to receive the **ST** command again within 'n' seconds of the last, and so on. If the **ST** command is not received within each time-out period, the output channel is set to the '0' (alarm) state. (The IMP is not reset.) Disabling causes the output to go into its '0' state. Once the watchdog is enabled, a powerdown forces the output into the '0' (alarm) state. The **RE** command does not disable the watchdog. **Note:** Enabling either watchdog causes the output to go into the '1' (no alarm) state. For the output to be disabled from the watchdog both the hardware and software watchdogs need to be disabled.

**Response** None.

---

## CH VO (CHannel Voltage Output)

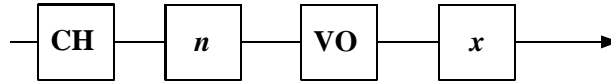

$n$  is an integer which defines the channel number, in the range  $1 \leq n \leq 4$ ,  
 $x$  is the output voltage in 4-byte floating-point format, in the range  $-10 \leq x \leq +10$ .

**Note** This command applies only to IMPs type '1D.

**Function** Sets the specified channel to the specified voltage.

**Response** None.

**See also** OS

---

## CH IO (CHannel Current)

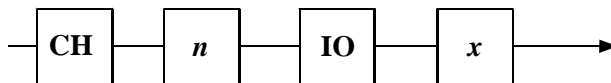

$n$  is an integer which defines the channel number, in the range  $1 \leq n \leq 4$ ,  
 $x$  is the output current (amps) in 4-byte floating-point format:

- in the range  $0.000 \leq x \leq 0.02$ , or
- in the range  $0.004 \leq x \leq 0.02$  if the split pad on connector block is made. (See the IMP Installation Guide).

**Note** This command applies only to IMPs type '1D.

**Function** Sets the specified channel to the specified current in amps.

**Response** None.

**See also** OS

---

---

## CH CV (CHannel Calibrate Voltage)

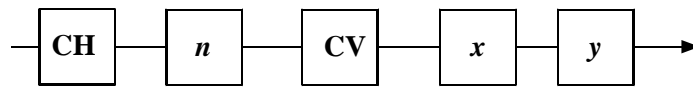

$n$  is an integer which defines the channel number, in the range  $1 \leq n \leq 4$ ,  
 $x$  = measured voltage value, corresponding to an uncalibrated 0V output.  
 $y$  = measured voltage value, corresponding to an uncalibrated 10V output.  
Values  $x$  and  $y$  are both in volts, in 4-byte floating-point format.

**Note** This command applies only to IMPs type '1D with a 3595 3Y connector block.

**Function** Allows voltage calibration of a specific output channel. This should normally be left to Solartron Instruments service personnel, or to those users with specialist reference equipment.

**Response** Stream 3, 4 characters **CnVe**, where  $n$  is the channel number and  $e$  represents the calibration response, as shown in Table 1.18.

**Table 1.18 Calibration Responses.**

e Code	Meaning
0	Calibration completed.
1*	Invalid range.
2	EEPROM fault: EEPROM missing or not working.
3	35953Y calibration connector block not fitted

\*  $e = 1$  is caused either by an arithmetic error in calculating the calibration coefficients or by the calculated coefficients not allowing the full range of the channel to be used. This means either that incorrect measurements were made or that there is a fault in the output circuitry of the IMP.

**Equipment** The calibration equipment required for the analog output IMP (type '1D) is:

- An analog output connector block (part no. 3595 3Y). This allows the IMP to recognize the calibrate commands.
- A stable temperature environment of  $20^{\circ}\text{C} \pm 3^{\circ}\text{C}$ . The IMP should be powered up and allowed to stabilize at this temperature, ideally for 24 hours.
- An accurate multimeter to measure the output channels.



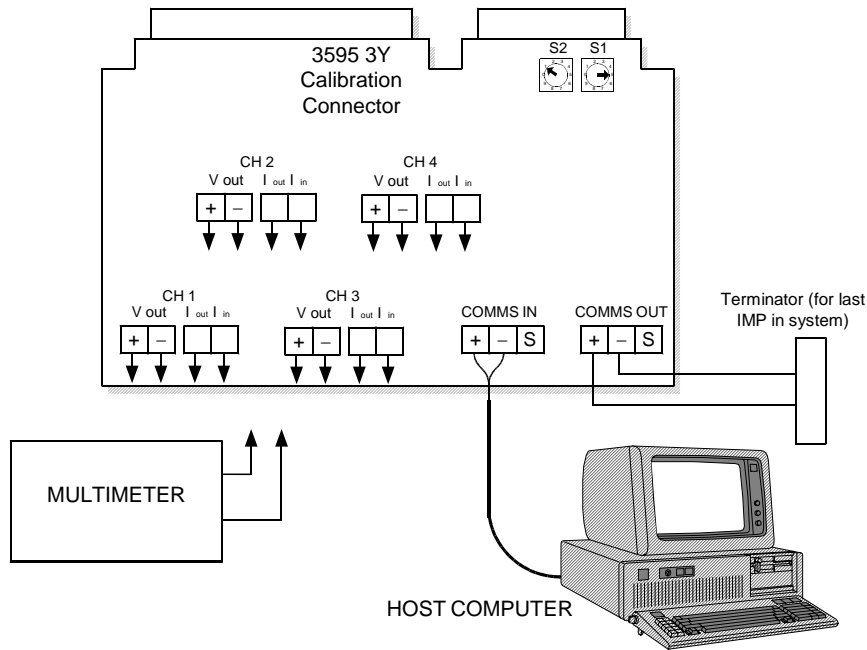

**Figure 1.2 Connections to 3595 3Y calibration connector block.**

**Procedure** The procedure for calibrating the output voltage of a '1D IMP is:

1. Fit all cables to the 3595 3Y calibration connector block PCB terminal connectors as shown in Figure 1.3.
  - a. The S-Net cable is connected to the 'COMMS IN' terminals. Strictly observe + to + and - to - polarity, and the S (screen) to S connections throughout the network.
  - b. The multimeter is connected to the channel to be calibrated.

**Note:** To avoid signal reflections, a terminator connector (Part No. 35900222) must be connected across the 'COMMS OUT' terminals of the last IMP on the system. (The terminator connector is supplied with the S-Net host interface package.)

2. Set the rotary address switches on the 3595 3Y calibration connector block PCB to a number between 01 and 50.
3. Insert the 3595 3Y calibration connector block into the IMP to be calibrated.
4. Power-up the host computer.
5. Turn the calibration mode off by sending **KA1** to the IMP.
6. Using the **CH VO** command, set the channel output voltage first to 0V and second to 10V and, in each case, measure the voltage actually output by the IMP.
7. Using the measurements obtained in Step 6, send the channel calibrate voltage command, **CHnCVxy**. In this command, *x* is the actual voltage

measured when 0V was requested and  $y$  is the actual voltage measured when 10V was requested.

8. Check the calibration response in stream 3 (see Table 1.18) to ensure that the IMP channel has been successfully calibrated.

---

## CH CI (CHannel Calibrate current)

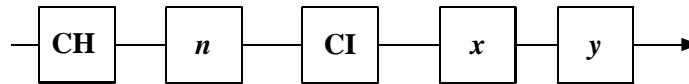

$n$  is an integer which defines the channel number, in the range  $1 \leq n \leq 4$ ,

$x$  = measured current value, corresponding to an uncalibrated 0.004A output.

$y$  = measured current value, corresponding to an uncalibrated 0.02A output.

Values  $x$  and  $y$  are both in amps, in 4-byte floating-point format.

- Note** This command applies only to IMPs type '1D with a 3595 3Y connector block.
- Function** Allows current calibration of a specific output channel. This should normally be left to Solartron Instruments service personnel, or to those users with specialist reference equipment.
- Response** Stream 3, 4 characters **CnIe**, where  $n$  is the channel number and  $e$  represents the calibration response, as shown in Table 1.18.
- Equipment** Same as for the **CH CV** command (above).
- Procedure** The procedure for calibrating the output current of a '1D IMP is:
- 1-5 Same as for **CH CV** command (previous).
  6. Using the **CH IO** command, set the channel output current first to 0.004A and second to 0.02A and, in each case, measure the current actually output by the IMP.
  7. Using the measurements obtained in Step 6, send the channel calibrate current command, **CHnCIxy**. In this command, 'x' is the actual current measured when 0.004A was requested and 'y' is the actual current measured when 0.02A was requested.
  8. Check the calibration response in stream 3 (see Table 1.18) to ensure that the IMP channel has been successfully calibrated.

---

## OS (Output Status)

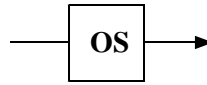

**Note** This command applies only to IMPs type '1D.

**Function** This command returns the status of the analog output channels.

**Response** Stream 3, 12 characters:

3	0			$d_1$	$e$	$d_2$	$e$	$d_3$	$e$	$d_4$	$e$
---	---	--	--	-------	-----	-------	-----	-------	-----	-------	-----

where,

digits  $d_1$ ,  $d_2$ ,  $d_3$  and  $d_4$  relate to channels 1, 2, 3 and 4, and are either V or I, depending on whether the last command sent to that channel was CH $n$ VO $x$  or CH $n$ IO $x$ .

$e$  represents the output status code, as shown in Table 1.19.

For example, '30 V0V0I0I0' shows that channels 1 and 2 have been correctly set for voltage output and channels 3 and 4 have been correctly set for current output.

**Table 1.19 Analog Output Status Codes.**

e Code	Meaning
0	OK (channel correctly set).
1	Kal mode on but calibration data corrupt.
2	Value requested is out of range.

$e = 1$  results if Kal mode is on (default), but the EEPROM is not fitted or the IMP is not yet calibrated.

If  $e$  is '1' or '2' then the last channel output command sent to that channel was not executed.

## 3.7 ADDITIONAL COMMANDS FOR UNIVERSAL IMPS '1H AND '1J

---

### 3.7.1 Definition of Terms

<i>Physical Channel</i>	These are the twenty channels present on the IMP connector block, in the range one through twenty.
<i>User Unit Conversion</i>	A simple first order conversion of the measured unit (resulting from CHannel MOde) to the required unit.
<i>User Linearization</i>	A fifth order linearization from the measured unit (resulting from CHannel MOde) to the required unit.
<i>Real Time Mode</i>	This is the 'standard' mode in which IMPs output their data: the messages are streamed and real-time results appear without a time-stamp in stream 0. For IMPs type '1A, '1B, '1C, '1D, '1E, '2A, and '2B this is the only mode available. The same mode can also be selected for IMPs type '1H and '1J, but for IMPs of this type two other modes are selectable: the <i>time tag</i> mode and the <i>historical</i> mode. (See below.)
<i>Time Tag Mode</i>	Same as above with an extended Stream 0 to include a time tag.
<i>Historical Mode</i>	This mode is unique to the '1H and '1J IMPs and does not use streams 0 and 1. Stream 2 is enlarged to fill the first 240 bytes of the receive page. All results, alarms etc. from the IMP are passed through with a time stamp. This mode must be used if buffering of IMP data during S-Net downtime is required. Stream 3 is preserved to return status and error information. ( <b>Do not</b> use the SA command to save the database while in continuous, historical mode, since this uses stream 0, and overlaps the same data space on the Interface.)
<i>Logic States</i>	<p>When channels 19 and 20 are used for digital (status) inputs the logic states recognized are:</p> <p>logic 1 = switch open (off) = high impedance</p> <p>logic 0 = switch closed (on) = low (zero) impedance</p> <p>When the IMP is powered off, the switch is high impedance, and is read as a '1' by another IMP. The digital channel output maintains this state until changed by a setup command.</p>

### 3.7.2 Command Descriptions

---

#### CH LR (CHannel Loop Resistance)

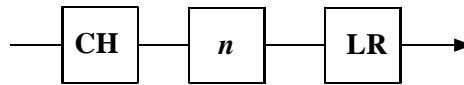

*n* an integer that defines the physical analog channel, in the range  $1 \leq n \leq 18$ .

**Function** Reports the loop resistance, between *high* and *low*, of a thermocouple on channel *n*. Channel *n* must be configured as a thermocouple type (MMode 310 - 3A4). If *n* is out of range the command does not return an error, but is ignored.

**Response** In stream 3:

CH n LR <4 byte result>

the result is in kohms – no time tag.

---

#### CH UC (CHannel Unit Conversion)

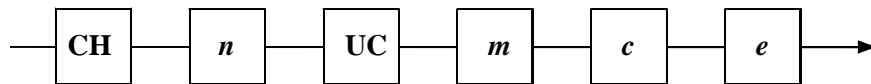

*n* an integer that defines the physical analog channel, in the range  $1 \leq n \leq 18$ ,

*m* an IEEE 754 floating-point number defining the slope of a line,

*c* an IEEE 754 floating-point number defining a constant (y axis cartesian intersection),

*e* an enable flag (1 = enable, 0 = disable).

**Function** Used to convert a measured parameter into alternative units with the function

$$y = mx + c$$

where *x* is the input parameter and *y* is the output.

- Notes**
1. The input parameter is post Channel Mode. Therefore if the required output is pressure, and the input is measured from a 4-20mA transmitter, two conversions are possible:
    - a. From a measured voltage across a precision resistor through which the current flows (unit conversion is post CHannel MMode voltage),
    - b. From a measured current through a 100Ω precision resistor (unit conversion is post CHannel MMode current).
  2. Once the measured parameter has been converted it is no longer available (as current or voltage for example).

---

## UT (User Thermocouple linearization)

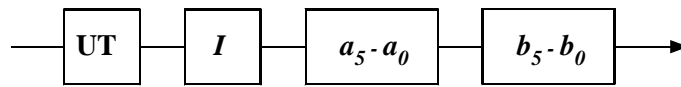

- I* defines the user thermocouple as Thermocouple '1' or '2',
- $a_5 - a_0$  IEEE 754 floating-point numbers for the coefficients of a fifth order polynomial,
- $b_5 - b_0$  IEEE 754 floating-point numbers for the coefficients of a fifth order polynomial, which is the inverse of the  $a_5 - a_0$  polynomial.

**Function** Used to apply user-defined linearization to a thermocouple measurement. The aim is to cover any thermocouple type not covered by the linearization polynomials currently programmed into the '1H and '1J IMPs. (Channel modes 390-394 use the coefficients defined by UT1 and channel modes 3A0-3A4 use the coefficients defined by UT2.) The computation of reference junction<sup>2</sup> compensation requires both the linearization polynomial and its inverse. User-defined thermocouple linearization acts in the same way as predefined thermocouple linearization with respect to the **AM**, **TE** and **TC** commands. See Table 1.7 (mode codes 310 - 3A4).

**Note** If a thermocouple is measured, but its corresponding linearization equation has not been defined, the error code FF82xxxx is returned in place of the 4 byte result.

**See also** CH MO

---

## CH PL (Post Linearization)

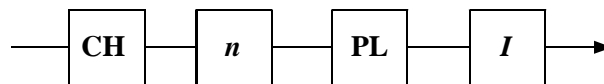

- n* an integer that defines the physical analog channel, in the range  $1 \leq n \leq 18$ .
- I* defines the user-defined linearization equation to use, '1' or '2'. ('0' disables post linearization on channel *n*.)

**Function** Enables conversion of a measured parameter into alternative units, with the linearization function  $y = a_5x^5 + a_4x^4 + a_3x^3 + a_2x^2 + a_1x + a_0$

where *x* is the measured input and *y* is the output. The Coefficients used are those defined by the **PL** command.

**Note** The CH PL command can be used with channel unit conversion. Post linearisation is applied first, and then unit conversion.

**See also** PL

---

<sup>2</sup> Originally called a *cold* junction, but *reference* junction is a more apt term. See Appendix A, 'Using a Thermocouple' in the 3595 Series IMP Installation Guide.

---

## PL (Post Linearize)

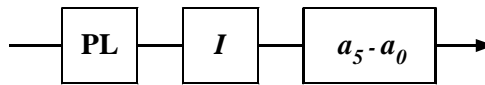

*I* specifies which linearization polynomial to define, '1' or '2'.

$a_5 - a_0$  IEEE 754 floating-point numbers for the coefficients of a fifth order polynomial.

**Function** Defines the coefficients of the polynomial that is applied by a **CH PL** command.

If the polynomial is undefined, the result returned is zero – not an error code.

**See also** CH PL

---

## CH HL (CHannel High Limit)



*n* an integer that defines the physical analog channel, in the range  $1 \leq n \leq 18$ .

*<limit>* an IEEE 754 floating-point number that defines the limit, in channel units

*<i>* an IEEE 754 floating-point number that defines the  $\pm$  limits for hysteresis (in units)

**Function** Defines the high limit for alarm checking on a channel. Used only in conjunction with the **CH GO** command.

The effect of hysteresis is described in the following example:

1. The limit for a thermocouple is set to 110° C.
2. Hysteresis is set to 3.
3. With a rising temperature, an alarm is signalled at 113° C. The signal remains until the temperature falls below 107° C.

**See also** CH LL, CH GO

---

## CH LL (CHannel Low Limit)

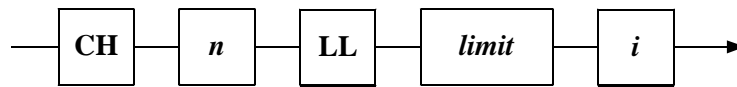

- n* an integer that defines the physical analog channel, in the range  $1 \leq n \leq 18$ .
- <limit>* an IEEE 754 floating-point number that defines the limit, in channel units
- <i>* an IEEE 754 floating-point number that defines the  $\pm$  limits for hysteresis (in units)

**Function** Defines the low limit for alarm checking on a channel. Used only in conjunction with the **CH GO** command.

The effect of hysteresis is described in the following example:

1. The limit for a thermocouple is set to 10° C
2. Hysteresis is set to 3
3. With a falling temperature, an alarm is signalled at 7° C. The signal remains until the temperature rises above 13° C.

**See also** CH HL, CH GO

---

## CH GO (CHannel Group alarm Output)

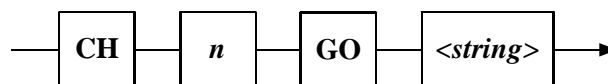

- n* The number of the digital output channel, 19 or 20.
- <string>* A string defining the analog channels on which an alarm check is to be made. The string has the format:

$$p A_1 A_2 A_3 \dots A_{36}$$

*p* defines the output state of channel *n* for alarm detected—

- p* = 2, Disable alarm checking on channel *n*,
- p* = 1, FET on: switch closed, i.e. as MODE 801,
- p* = 0, FET off: switch open, i.e. as Mode 800.

*A* is the identity of an alarm check and consists of an analog channel number, in the range 1-18, and the character H or L. 'H' specifies a high alarm check and 'L' a low alarm check. For example, '01H' specifies a high alarm check on channel 1, whilst '01L' specifies a low alarm on the same channel.

**Function** Defines the group of alarms to be associated with a digital output. If any of the alarms are active (OR logic) the digital output will be active. Only the channels specified in the last **CH GO** command are checked.



The **CH GO** command provides for alarm checking on all 18 analog channels, against the high and low limits defined by the **CH HL** and **CH LL** commands. On all analog channels it is possible to specify a high alarm check, or a low alarm check, or both. Specifying both alarm checks is equivalent to specifying an ‘out-of-window’ check. (Note that it is not possible to specify an ‘in-window’ check by specifying a high limit that is less than the low limit.)

#### NOTES

1. If  $n = 20$ , Watchdogs are disabled.
2. Alarm checking operates only for scanned channels, NOT for single measurements.
3. The **CH GO** command stays in operation unless
  - a. it is overridden by a **CH MO** command, OR
  - b. another **CH GO** command is received, OR
  - c. the Watchdog is enabled (Ch 20 only). This command sets the MOde database to  $MO80x$ , where  $x$  = the GO state for the channel.
4. The state of a digital output may be read at any time by measuring or scanning the channel.
5. The group may consist of one alarm element only. If  $p=2$ , no alarms need be specified –alarm checking is disabled for all alarms previously specified.
6. On alarm the defined digital output is active. ‘Active’ can be defined as ‘switch closed’ or ‘switch open’, depending on the value of  $p$  in the command string. This gives the option of an active alarm when the IMP is non-functional.

Consider, for example, a requirement to disable a machine when off-limit readings are obtained for oil temperature, oil pressure, or both, or when the monitoring equipment is non-functional. The oil temperature should be in the range  $-10$  to  $+95^{\circ}\text{C}$ , and the oil pressure should be in the range 1 to 3 bar. The channel definitions for this could be:

- a. Minimum acceptable oil temperature on channel 1 (low limit): **CH1LL-10**.
- b. Maximum acceptable oil temperature on channel 1 (high limit): **CH1HL95**.
- c. Minimum acceptable oil pressure on channel 2 (low limit): **CH2LL1**
- d. Maximum acceptable oil pressure on channel 2 (high limit): **CH2HL3**
- e. Define channel 19 associated with the above alarm group:  
**CH19GO001L01H02L02H**

(Note that alarms use data post-unit conversion or post-linearization.)

While the IMP is powered down the digital output is open, thus disabling the machine. When the IMP first powers up the machine remains disabled. When the **CH19GO** command is sent, the output is switched into the alarm state (no change in this case) thus disabling the machine. Once the IMP has read the machine parameters and determined that none are in alarm it closes the output switch, thus enabling the machine.

**See also**    **CH HL, CH LL**

---

## AS (Auto-Start)

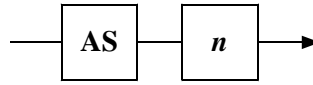

$n = 0$  False – do not auto-start. (default)

$n = 1$  True – auto-start.

**Function** When auto-start is set true the IMP automatically begins operations after a hard reset (power-up or a hardware watchdog timeout).

After a hard reset, and just before entering an idle loop, the IMP checks the value of  $n$  in its non-volatile database. If  $n$  is true, the non-volatile database is restored to the database proper, as if an **RD** command had been issued. A check is then made of the CONTINUOUS\_SCANNING boolean variable: if this is true, a scan is triggered automatically; if it is false, then no further action is taken. If AS is false no action is taken.

**Example** A typical **AS** command sequence is:

1. **SE** – set up the imp to default mode.
2. **CO** – set continuous triggering.
3. **AS1** – set auto-start true.
4. **SD** – save the settings in non-volatile memory.

These commands prepare an IMP to respond to a hard reset by restoring its database and issuing a trigger command to itself.

---

## RM (Result Mode)



$n = 0$  Real-time mode (default).

$n = 1$  Real-time with time tag. As above, but with an extended stream 0 which includes a time tag.

$n = 2$  All results returned in a stream 2 (historical).

**Function** Mode 0 outputs data, on Stream 0, in the same format as for all IMPs. Mode 1 outputs the same data but with a time-tag. Mode 2 outputs historical data on Stream 2, and allows all 960 buffers to be used. Each buffer holds a scan of 20 channels. If, for example, the scan period is set, with the **SP** command, to 10s then the 960 buffers will be filled in 9600s (= 2hrs 40mins).

Historical mode buffering operates on a first in, first out basis (FIFO). If the IMP is measuring faster than the host can read the results, then the results are stacked in the FIFO buffer. When the buffer is full the IMP continues measuring so that it can monitor its alarm inputs, but it does not store the results in the buffer until space becomes available.

---

---

## FB (Flush Buffers)

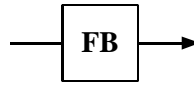

**Function** Flushes the historical results FIFO and returns the FIFO to the free buffers list. **FB** is a one shot command, and has no persistent effect. For further flushing, another **FB** command must be sent.

---

## SD and RD (Save Database and Restore Database)



**Function** The **SD** and **RD** commands provide for a quick setup.

The **SD** command saves the database of a previously configured IMP into a flash PROM. At a later date, the **RD** command can be used to load the current contents of the flash PROM into the database proper.

When the database is restored, two things happen:

1. The watchdogs are disabled.
2. If the channel mode is 80x, the output is set accordingly.

(Refer to Appendix A for details of the database format.)

Compared with the Host saving and restoring the IMP database over S-Net the above method is more convenient, but less flexible.

**Response** Stream 3. Single character H (SD only). This response confirms that the database has been written.

**Note** Before storing the database in the flash PROM, the SD command generates an internal Halt command. This does not change the state of the COntinuous Scan Parameter.

While the database is being stored there is no communication with the IMP and S-Net. This causes polling errors, which stop when storage is complete.

It can take up to three seconds for the IMP database to be stored. Therefore, after sending the SD command, any software program should wait three seconds, clear the error flags from the interface and then read Stream 3 for an H character. Once this is received, the IMP is ready to resume normal operations.

---



Before an IMP can take a measurement it must first be assigned a task and enabled (set-up). Only then can an IMP be instructed to take a measurement. Each result must then be read, otherwise buffer space will be filled until the IMP no longer has room to store new data, and measurements will stop.

The command language used by the IMPs is very versatile, allowing great flexibility in the way each IMP/channel can be configured and used. To assist in preparing an application program, suggested command procedures that can be applied to an IMP are outlined overleaf. The detailed function and syntax of each command is covered by the appropriate entry in the Command Directory. As users become more familiar with the commands available, more complex procedures can be tailored to suit individual applications.

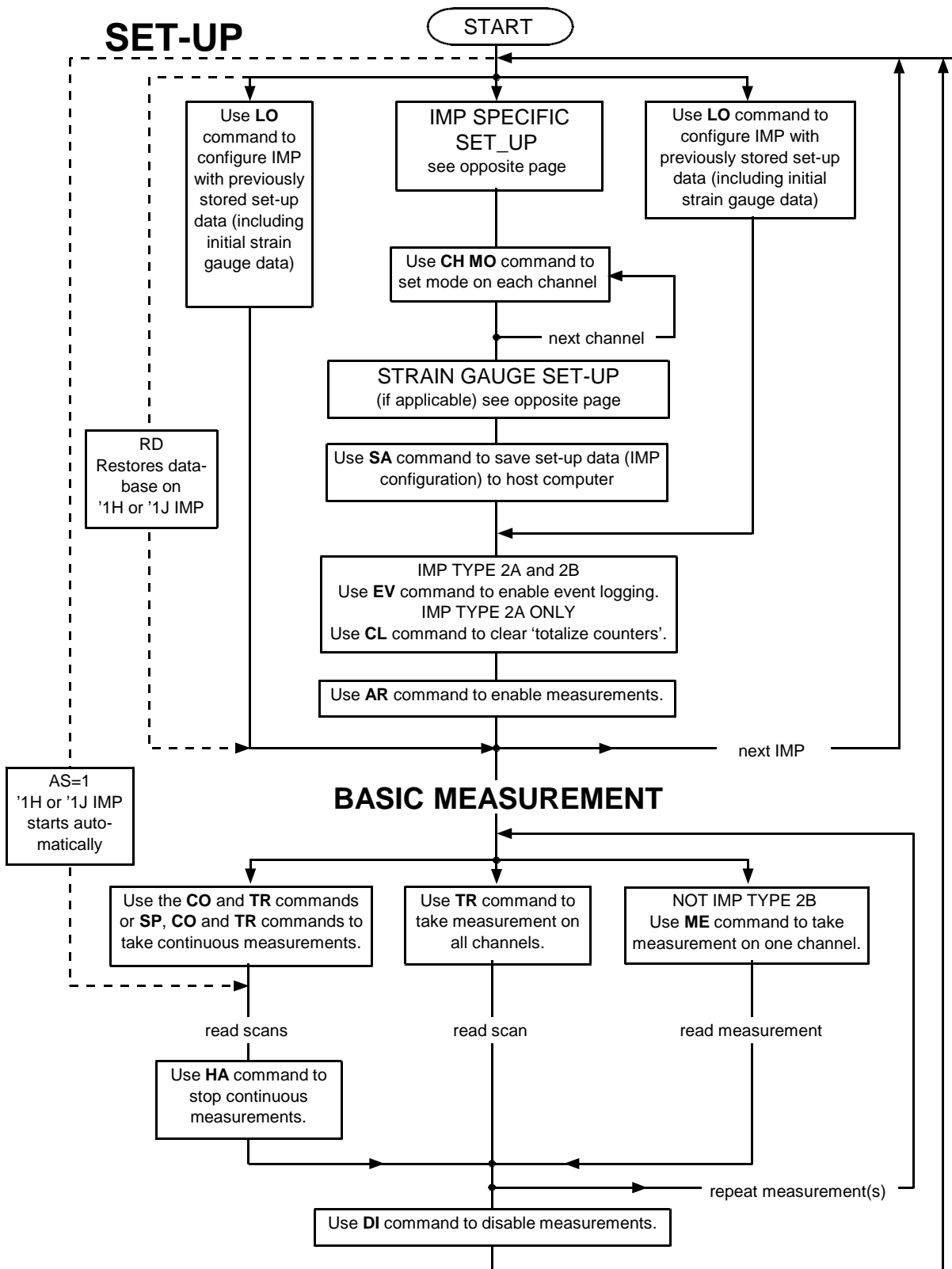

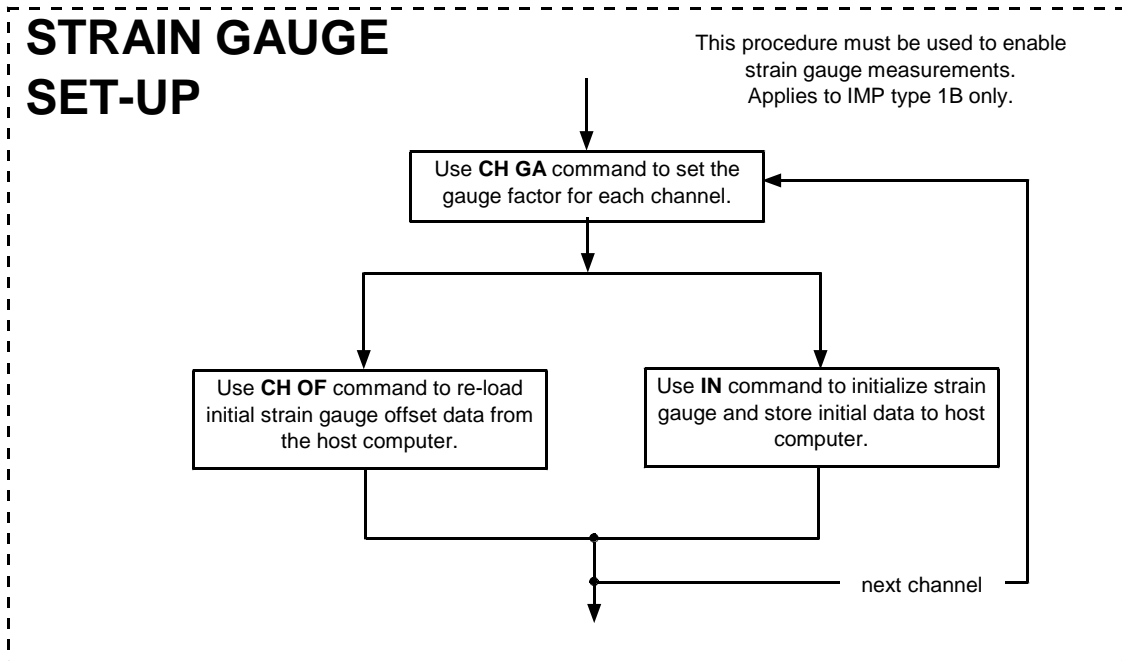
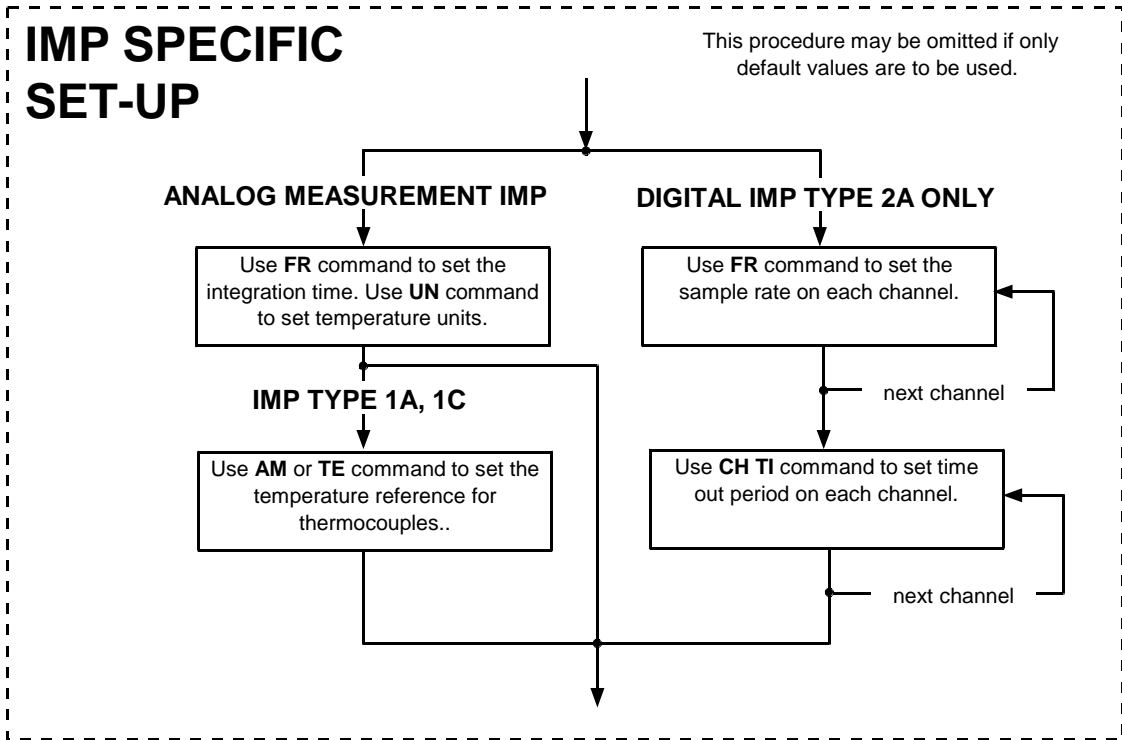





# Result and Error Formats

## Contents

<b>1</b>	<b>Introduction</b> .....	2-3
<b>2</b>	<b>IEEE 754 Floating-Point Format</b> .....	2-4
<b>3</b>	<b>Four-Byte Result Format</b> .....	2-5
<b>4</b>	<b>Event Result Format</b> .....	2-6
4.1	Bookmark Format .....	2-7
4.2	Event Tag Format .....	2-7
4.3	Event Status Format .....	2-8
4.4	End Tag Format .....	2-8
4.5	Lost Event Result Format .....	2-8
<b>5</b>	<b>Time Tag Formats (for '1H and '1J IMPs)</b> .....	2-9
5.1	Bookmark Format .....	2-9
5.2	Time Tag Format .....	2-9
<b>6</b>	<b>Historical Data Formats (for '1H and '1J IMPs)</b> .....	2-10
6.1	Historical Data Stream .....	2-10
6.2	Bookmark Format .....	2-10
6.3	Time Tag Format .....	2-11
6.4	End Tag Format .....	2-11
<b>7</b>	<b>IMP Error Messages</b> .....	2-12

## **List of Tables**

<i>Table 2.1 IMP Result Formats</i> .....	2-3
---	-----

# 1 INTRODUCTION

---

Table 2.1 summarises the result formats applicable to IMPs type '1A, '1B, '1C, '1D, '1E, '2A and '2B.

**Table 2.1 IMP Result Formats**

IMP Result	Stream	Format
Scan data of all measurements, <i>except event totalise and event increment</i> .	0	Four-byte floating-point format. (See Section 3.)
Scan data of event totalise and event increment measurements.	0	IEEE 754 floating-point format. (See Section 2.)
Single Measurement.	1	Four-byte floating-point format. (See Section 3.)
Event capture. (From '2A and '2B IMPs only.)	2	Event capture results are returned in the form of <i>bookmarks, event tags, event status, end tags and lost events</i> . Each of these has its own peculiar format, which is described in Section 4.
IMP status and Command responses	3	ASCII characters.
Response to an SA (SAve setup data) command.	0	Command format. (See chapter 1, 'IMP Commands'.)

For IMPs type '1H and '1J the same formats apply, but, depending on the result mode selected for these particular IMPs, the results may be time-tagged.

The three result modes of the '1H and '1J IMPs are:

- real-time*** – exactly the same format as for all other IMPs.
- time-tagged*** – each scan data block, or single measurement result, has a *bookmark* and *time tag* appended,
- historical*** – allows the IMP to pass historical time-tagged results back to the Host.

The format of the bytes appended in the *time-tagged* and *historical* modes above are described in Sections 5 and 6.

The **error messages** that may be returned by any IMP are listed in Section 7, together with their meanings.

## 2 IEEE 754 FLOATING-POINT FORMAT

The IEEE 754 floating-point format is used for the event totalise and event increment results returned by '2A and '2B IMPs. It is also used for the response to the IN command, and for the setup parameters in some commands. To represent a number the IEEE 754 floating-point format uses four bytes:

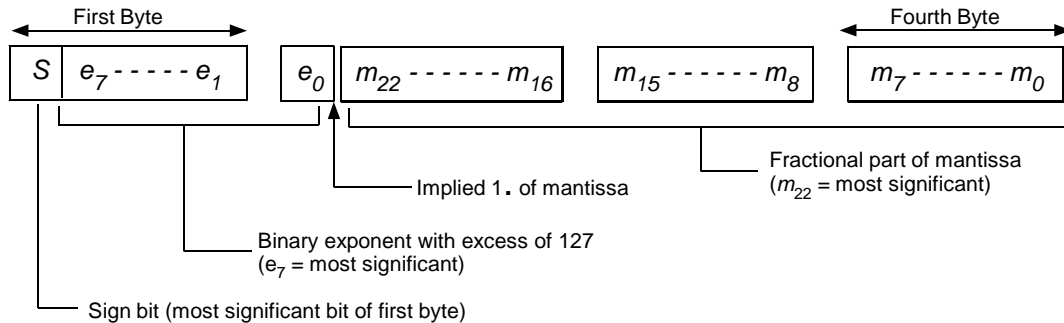

The sign bit is one if the number is negative, zero if the number is positive. The binary exponent has an excess of 127<sub>10</sub>. This means that it consists of the sum of the true exponent with 127<sub>10</sub>. This allows a range of exponent values from -127<sub>10</sub> to 128<sub>10</sub>. To retrieve the true exponent subtract 127<sub>10</sub>. The mantissa has an 'implied one'. Only the fractional part of the mantissa is actually written. When the number is converted to IEEE format the exponent is adjusted until there is only a single binary one to the left of the binary zero. This binary one is then omitted and becomes 'implied'.

**Example** To convert a decimal number of 2.25:

$$2.25_{10} = 10.01_2 = 10.01 \times 2^0 = 1.001 \times 2^1$$

Mantissa (with implied 1)	= .001
Exponent	= 1
with excess of 127	= 127+1 = 128

This gives the result:



The result breaks down into:

Sign bit = 0, therefore the number is positive.  
 An exponent with excess of 127<sub>10</sub> = 10000000<sub>2</sub> = 128<sub>10</sub>.  
 , the true binary exponent is 1<sub>10</sub>.  
 Mantissa with implied 1 = 001 . . . .  
 , a true mantissa of 1.001<sub>2</sub>.

The four bytes therefore represent:

$$1.001_2 \times 2^1 = 10.01_2 = 2.25_{10}$$

**Note:** Zero is represented by all four bytes being 'all zeroes'.

### 3 FOUR-BYTE RESULT FORMAT

Analog and digital data are sent in a four-byte result format that closely resembles the IEEE 754 format.

The 'four-byte' format differs from the IEEE 754 format in having a shorter mantissa, that is 17 bits (rather than 23). Four of six bits thus freed are used to hold information on the significance of the result, as follows:

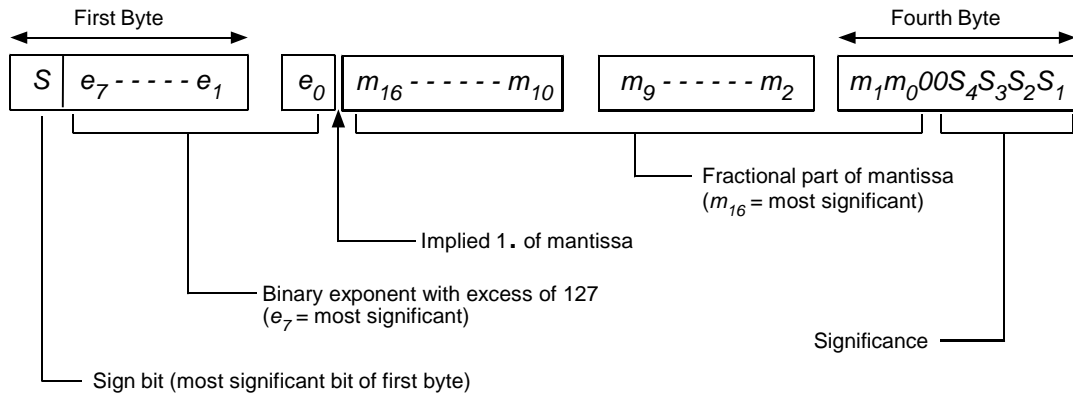

The significance is the number of valid decimal places in the result. This is decided by the range selected in the IMP.

## 4 EVENT RESULT FORMAT

---

Event results are obtainable only from digital IMPs (type '2A) and switch IMPs (type '2B) that are set up for event capture. The '2A IMP can store up to 6000 bytes of event data, whilst the '2B can store up to 512 bytes. Both types can transmit up to 112 bytes of event data at a time.

Event data carries information on the time and direction of change of a digital signal. The time of a detected event is referenced to the IMP's internal calendar (and clock), which is regularly synchronised, from the Interface, by the system clock in the Host. Synchronism is carried out regularly and does not affect measurement integrity.

Event data is transmitted in stream 2. If the Interface input buffer for Stream 2 and the relevant IMP is empty then event data is transmitted as soon as it occurs. If, however, the input buffer already holds unread data then the IMP stores results and transmits the event data when the buffer is free.

Event data consists of:

- Bookmarks.** Four bytes containing the calendar month, day, hour and minute.
- Event tags.** Four bytes containing the channel number, direction of transition, calendar seconds and milliseconds. One event tag is sent per event.
- End tags.** Four bytes containing only binary zeroes. This indicates the end of a set of event data, and is used when less than 112 bytes of event data is transmitted.
- Lost event results.** When the event storage area of the IMP and the input buffer of the Interface are full, the IMP has nowhere to send or store event results. Instead, it counts the number of events that occur. This data is stored in a 4 byte result and loaded it into the output buffer when space is available. Up to 65535 lost events can be counted.

Event data transmitted by an IMP can consist of a number of bookmarks, event tags and one end tag. Only a single bookmark is sent per calendar minute (and this only if an event occurs). A bookmark gives the most significant calendar data for all event tags sent after it, until the next bookmark is sent.

If event data is sent to a free Interface buffer then data for only one result is sent: this consists of a bookmark, an event tag and an end tag. Subsequent data is sent only if the application program reads this initial data. The IMP, whilst waiting for buffer area to become free, stores any new event tags and bookmarks. This data is sent when the buffer is free. An end tag is added if the stream of event data is less than 112 bytes long, but this tag can be replaced by a lost event tag if one is to be sent.

Event status responses also go into stream 2. In this case the event tag is replaced by the event status format.

## 4.1 BOOKMARK FORMAT

A bookmark contains the calendar month, day, hour and minute, in the following format:

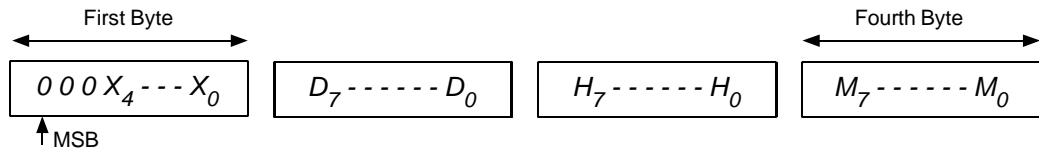

All numbers are in binary coded decimal:

X <sub>4</sub>	months, tens
X <sub>3</sub> ..... X <sub>0</sub>	months, units
D <sub>7</sub> ..... D <sub>4</sub>	days, tens
D <sub>3</sub> ..... D <sub>0</sub>	days, units
H <sub>7</sub> ..... H <sub>4</sub>	hours, tens
H <sub>3</sub> ..... H <sub>0</sub>	hours, units
M <sub>7</sub> ..... M <sub>4</sub>	minutes, tens
M <sub>3</sub> ..... M <sub>0</sub>	minutes, units

## 4.2 EVENT TAG FORMAT

An event tag contains the channel number, direction of transition and the calendar seconds and milliseconds, in the following format:

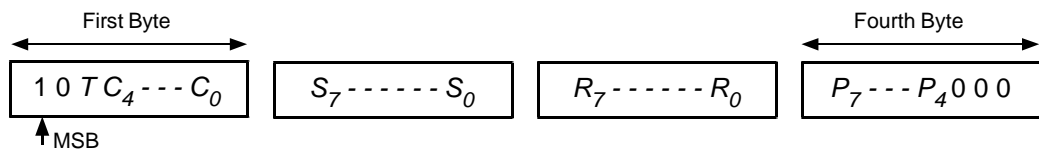

T = transition:                    if T = 1 then the event is positive-going (low to high)  
     if T = 0 then the event is negative-going (high to low)

C<sub>4</sub> ..... C<sub>0</sub>                    channel number, binary, (C<sub>4</sub> most significant)

**Note:** Channel numbers entered for the '2A IMP correspond exactly with the physical channels: 1 = Channel 1, 2 = Channel 2, and so on. With the '2B IMP, however, channel numbers 0 through 31 represent the physical channels 1 through 32.

All remaining numbers are in binary coded decimal:

S <sub>7</sub> ..... S <sub>4</sub>	seconds, tens
S <sub>3</sub> ..... S <sub>0</sub>	seconds, units
R <sub>4</sub> ..... R <sub>7</sub>	milliseconds, hundreds
R <sub>3</sub> ..... R <sub>0</sub>	milliseconds, tens
P <sub>7</sub> ..... P <sub>4</sub>	milliseconds, units

### 4.3 EVENT STATUS FORMAT

Event status information is similar to that contained in an event tag. The only difference is that the event status contains the event level instead of the event transition; all other information is the same.

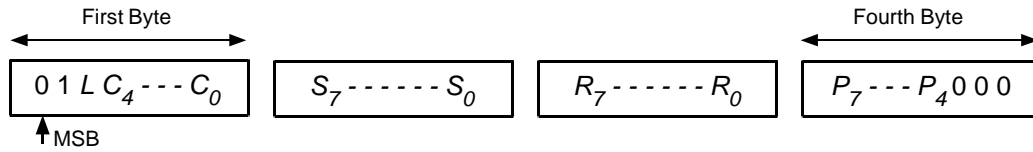

$L$  = status level:           if  $L=1$  then status = high  
   if  $L=0$  then status = low

$C_4 \dots\dots\dots C_0$            channel number, binary, ( $C_4$  most significant)

**Note:** Channel numbers entered for the '2A IMP correspond exactly with the physical channels: 1 = Channel 1, 2 = Channel 2, and so on. With the '2B IMP, however, channel numbers 0 through 31 represent the physical channels 1 through 32.

All remaining numbers are in binary coded decimal:

$S_7 \dots\dots\dots S_4$            seconds, tens  
 $S_3 \dots\dots\dots S_0$            seconds, units  
 $R_4 \dots\dots\dots R_7$            milliseconds, hundreds  
 $R_3 \dots\dots\dots R_0$            milliseconds, tens  
 $P_7 \dots\dots\dots P_4$            milliseconds, units

### 4.4 END TAG FORMAT

An end tag indicates the end of a set of event data and is used when less than 112 bytes are transmitted. The format is as follows:

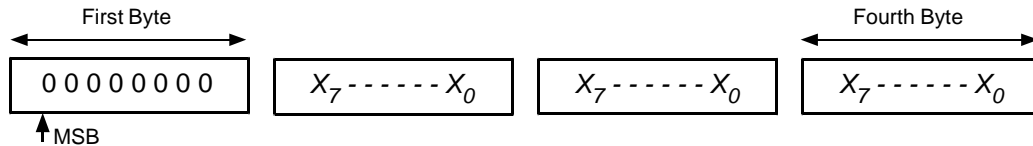

$X$  = any number (0 or 1)

### 4.5 LOST EVENT RESULT FORMAT

The lost event result contains the number of events lost due to the Interface input buffer being full. The format is as follows:

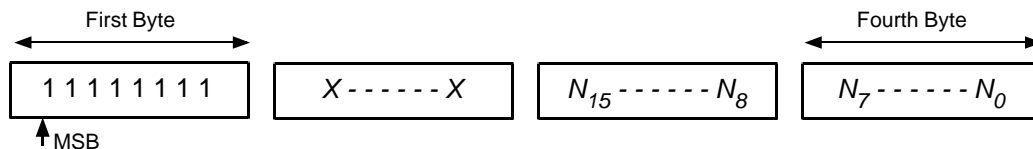

$N_{15} \dots\dots\dots N_0$        = Number of event results lost (binary,  $N_{15}$  = most significant bit)

$X$  = any number (0 or 1)



## 5 TIME TAG FORMATS (FOR '1H AND '1J IMPS)

With the result format set to *time tag*, the results from '1H and '1J IMPs are returned with a bookmark and time tag appended. These appear at the end of each scan and at the end of each single measurement. The formats of the bookmark and time tag are described in Sections 5.1 and 5.2 below.

### 5.1 BOOKMARK FORMAT

A bookmark contains the calendar month, day, hour and minute. The format is:

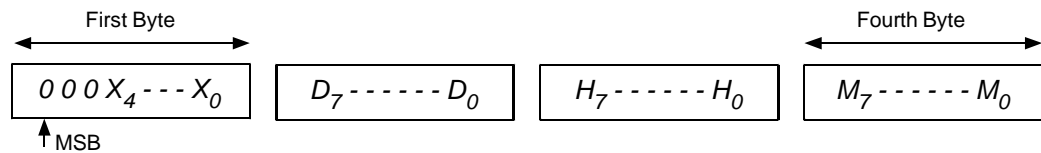

All numbers are in binary coded decimal:

$X_4$  months, tens  
 $X_3 \dots\dots\dots X_0$  months, units

$D_7 \dots\dots\dots D_4$  days, tens  
 $D_3 \dots\dots\dots D_0$  days, units

$H_7 \dots\dots\dots H_4$  hours, tens  
 $H_3 \dots\dots\dots H_0$  hours, units

$M_7 \dots\dots\dots M_4$  minutes, tens  
 $M_3 \dots\dots\dots M_0$  minutes, units

### 5.2 TIME TAG FORMAT

The time tag contains the calendar seconds and milliseconds, in the following format:

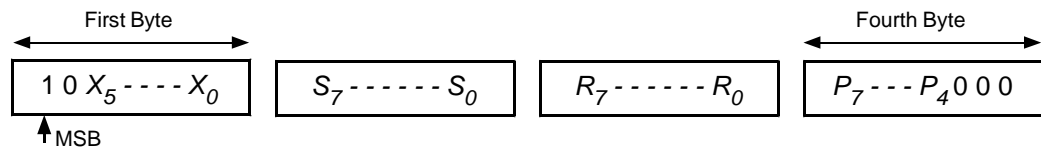

$X_5 \dots\dots\dots X_0$  don't care

All numbers are in binary coded decimal:

$S_7 \dots\dots\dots S_4$  seconds, tens  
 $S_3 \dots\dots\dots S_0$  seconds, units

$R_4 \dots\dots\dots R_7$  milliseconds, hundreds

$R_3 \dots\dots\dots R_0$  milliseconds, tens  
 $P_7 \dots\dots\dots P_4$  milliseconds, units

## 6 HISTORICAL DATA FORMATS (FOR '1H AND '1J IMPS)

With the result format set to *historical*, the results from '1H and '1J IMPs are preceded with a bookmark and time tag. These are described in Sections 6.2 and 6.3 below.

Also, to increase data throughput, and thus allow the historical data buffer to be emptied quickly after a temporary loss of S-Net, the data streaming is completely reorganised. This allows up to 240 bytes of scan or single measurement data to be passed back to the Host, in Stream 2, for every poll. Data streaming for historical results is described in Section 6.1 below. The end of useful data in Stream 2 is defined by an *end tag*. This is described in Section 6.4.

### 6.1 HISTORICAL DATA STREAM

Historical data is carried on Stream 2. This is enlarged to 240 bytes, so that more than one scan, and possibly some single measurements, can be returned per poll.

After a temporary loss of S-Net, the enlarged Stream 2 allows the Host to extract data from the historical data buffer as quickly as possible, and to get up to date with real-time measurements as they are made. (Unwanted historical data may be flushed out.)

Stream 0 is not used (except for the special case of SA) and Stream 1 is not used, but Stream 3 is retained and resides at the top of the data page.

Stream 2 never splits scan result blocks across a page. Therefore, after a loss of communication, and while extracting buffered scans, Stream 2 contains one or two scans worth of data (and possibly some MEasure results). The end of useful data is marked with an end tag. Note that this does not imply that there is no more historical data to extract, but that the last piece of useful data has been read from the page.

### 6.2 BOOKMARK FORMAT

A bookmark contains the calendar month, day, hour and minute. The format is:

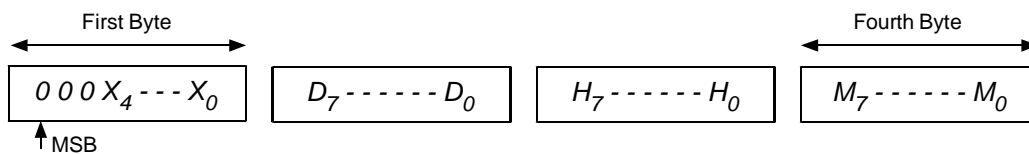

All numbers are in binary coded decimal:

X <sub>4</sub>	months, tens
X <sub>3</sub> ..... X <sub>0</sub>	months, units
D <sub>7</sub> ..... D <sub>4</sub>	days, tens
D <sub>3</sub> ..... D <sub>0</sub>	days, units
H <sub>7</sub> ..... H <sub>4</sub>	hours, tens
H <sub>3</sub> ..... H <sub>0</sub>	hours, units
M <sub>7</sub> ..... M <sub>4</sub>	minutes, tens
M <sub>3</sub> ..... M <sub>0</sub>	minutes, units

### 6.3 TIME TAG FORMAT

The time tag contains an indication of whether the following data is a scan or a single measurement, the channel number, and the calendar seconds and milliseconds, in the following format:

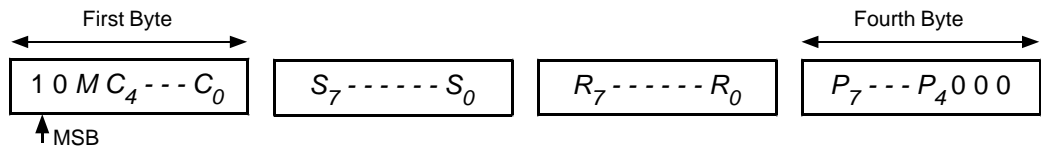

*M* if *M* = 0 then a single measurement follows the time tag.  
if *M* = 1 then a scan follows the time tag.

C<sub>4</sub> ..... C<sub>0</sub> channel number, binary. [not used if m=1 (scan)]

All the remaining numbers are in binary coded decimal:

S<sub>7</sub> ..... S<sub>4</sub> seconds, tens  
S<sub>3</sub> ..... S<sub>0</sub> seconds, units

R<sub>4</sub> ..... R<sub>7</sub> milliseconds, hundreds

R<sub>3</sub> ..... R<sub>0</sub> milliseconds, tens  
P<sub>7</sub> ..... P<sub>4</sub> milliseconds, units

### 6.4 END TAG FORMAT

An end tag in historical data indicates that there is no more data following it in the data page. The format is as follows:

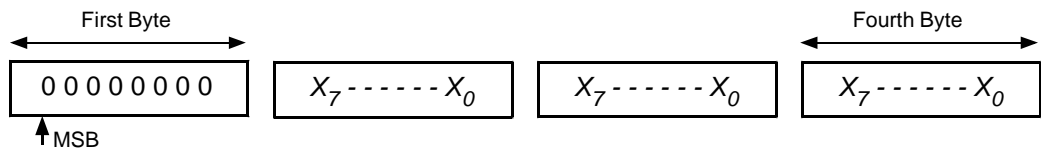

X = any number (0 or 1)

Note that the end tag does not imply that there is no more historical data to extract, but that the last piece of useful data has been read from the page.

## 7 IMP ERROR MESSAGES

---

Error messages are transmitted by an IMP in place of a 4-byte result. They occur only in response to a **ME**asure or **TR**igger command.

An error message is in the form of a 4-byte analog result with a negative sign and an exponent of 255. In hexadecimal this is represented by any number in excess of FF 80 00 00. In IEEE floating point format this is equivalent to 'not a number'.

Hex.FF81 xxxx	Analog overload. The input to an analog measurement channel has exceeded the maximum value of the present range.
Hex.FF82 xxxx	User thermocouple undefined. Returned when a channel mode is set to 39x or 3Ax, but the corresponding thermocouple has not been defined. ('1H and '1J IMPs only)
Hex.FF83 xxxx	Out of linearization range. Returned by a thermocouple channel when the temperature is out of the measureable range.
Hex.FF84 xxxx	Ambient measurement range. The IMP has been instructed to use a temperature reference outside the permitted range (-30°C to +80°C).
Hex.FF85 xxxx	Transducer error. The IMP analog to digital converter is unable to decide a value. This error is commonly due to an open-circuit input or to a large over-voltage.
Hex.FF86 xxxx	Open circuit thermocouple error. Open-circuit thermocouple checking is enabled and the IMP has detected a failure.
Hex.FF87 xxxx	Unknown mode, type or range. The IMP has been instructed to select an inapplicable channel mode or an unsupported integration time.
Hex.FF88 xxxx	This error code is unassigned.
Hex.FF89 xxxx	Channel number out of range. A channel number, n, outside the permitted range, has been specified. The permitted range is 1≤n≤10 for IMP type '1B or 1≤n≤20 for IMP types '2A, '1A, '1C, '1H and '1J.
Hex.FF8A xxxx	System zero error. The IMP is unable to perform a drift correction.
Hex.FF8B xxxx	System calibration corrupt. The calibration constants (including backup values) held in non-volatile memory show 'read errors'. non-volatile memory is either corrupt or not fitted.
Hex.FF8C xxxx	Strain gage not initialized. The IMP database must be loaded with the gage offset resistance and factor. See the Command Directory entry for <b>IN</b> . (Relevant only to '1B IMPs)
Hex.FF8D xxxx	Digital result pending. ('1H and '1J IMPs only)
Hex.FF8E xxxx	Period time-out. The IMP has tried to measure a time period but took longer than the maximum time allowed (set by the <b>CH.TI</b> command).
Hex.FFFF xxxx	Not measured The channel has been set to 'skip', 'digital output', or event capture.

The remainder of possible error codes are unassigned.

## *Database Structure ('1H and '1J IMPs)*

### **Contents**

<b>1</b>	<b>Database Structure .....</b>	<b>A-3</b>
----------	---------------------------------	------------



# 1 DATABASE STRUCTURE

---

The IMP uses a floating point format similar to IEEE, but not Quite. It is as Follows:

[SEEEEEEE|MMMMMMMM|MMMMMMMM|MMMMMMMM]

S = sign bit  
E = 7 bit exponent - excess 64  
M = 24 bit mantissa - *no hidden bits*.

**Note:** Where a parameter is stated as being a value, 0,1, 2 and so on, it is stored in the database in binary code, not ASCII.

```
#define TRUE          1          /* define Boolean Constants */
#define FALSE        0
#define CA_DISABLED  2          /* Disable Alarm Checking*/
#define CA_ASSERT    1          /* Turn Fet On, AS Mode 801 (Logic 0)*/
#define CA_DISASSERT 0          /* Turn Fet Off, As Mode 800 (Logic 1)*/
```

```
typedef unsigned char BYTE;
typedef unsigned char BOOL;
typedef float IMPFP
```

```
/******          Typedefs for DATABASE 1 - 12 Bytes          *****/
```

```
typedef struct
{
    BOOL    Armed;          /* AR Pod Armed */
    BOOL    Cont;          /* CO Continuous Scanning */
    BYTE    Driff;         /* DR 0,1 or 2 */
    BYTE    Cali;          /* KA 0 or 1 */
    BYTE    Units;         /* UN 0 or 1 */
    BYTE    UK_USA;        /* FR - See Below */
    IMPFP   Ex_ref[4];     /* TE in IMPFP Format */
    BOOL    Tcref;         /* TRUE if TE, FALSE if AM */
    BYTE    ResultMode;    /* RM 0,1 or 2 */
}DB1, *DB1_PTR;
```

```
/* The FR value is obtained by shifting the binary argument one place to the right
 * and inserting the carry bit into bit 4.*/
```

```
/******          Typedefs for DATABASE 2 - 86 Bytes          *****/
```

```
typedef struct
{
    /* Post Linearisation Enabled */
    BYTE    num[18];
    /* num = 0,1 or 2 */
}POSTLIN, *PL_PTR;
```

```
typedef struct
{
    BYTE    val[21];          /* Byte 0 for Internal Use */
}MODE, *MD_PTR;
```

```

typedef struct
{
    BOOL      AutoStart;          /* Set by AS Command */
    BYTE      Dbnce19;           /* CH n RAtE Setting */
    BYTE      Dbnce20;
    BYTE      Timeout19;        /* CH n TImeout setting */
    BYTE      Timeout20;
    POSTLIN   PostLin;          /* Post linearisation Enabled */
    MODE      Type;              /* Components of the .. */
    MODE      Mode;              /* CH n MO command */
    MODE      Range;
}DB2, *DB2_PTR;

/* Type is the First parameter, Mode the Second, and Rate the Third parameter of the
*CH n MO TMR command. Exceptions are noted below.
*
* 1) Range = Parameter -1, Except for 0 (Autorange, which is 0x82)
* 2) Modes 701 & 702 are stored as 7,1,82 & 7,2,82 respectively.
* 3) 'A' for User defined Thermocouple is 0x0a
*/

```

\*\*\*\*\* Typedefs for DATABASE 3 - 165 Bytes \*\*\*\*\*

```

typedef struct
{
    BOOL      Enabled;
    IMPFP     m ;
    IMPFP     c ;
} UC, *UC_PTR;

```

```

typedef struct
{
    BYTE      ScanPeriod[3];     /* Integer Milleseconds */
    UC        Conversions[18];
}DB3, *DB3_PTR;

```

\*\*\*\*\* Typedefs for DATABASE 4 - 146 Bytes \*\*\*\*\*

```

typedef struct
{
    BOOL      DEFINED;          /* This thermocouple is defined*/
/* Volts to temperature equation*/
    IMPFP     VT_PWR_5;         /* Multiplication Factor for x^5*/
    IMPFP     VT_PWR_4;         /* Multiplication Factor for x^4*/
    IMPFP     VT_PWR_3;         /* Multiplication Factor for x^3*/
    IMPFP     VT_PWR_2;         /* Multiplication Factor for x^2*/
    IMPFP     VT_PWR_1;         /* Multiplication Factor for x^1*/
    IMPFP     VT_C;              /* Constant addition*/
/* Temperature to volts equation for cold junction compensation */
    IMPFP     TV_PWR_5;         /* Multiplication Factor for x^5*/
    IMPFP     TV_PWR_4;         /* Multiplication Factor for x^4*/
    IMPFP     TV_PWR_3;         /* Multiplication Factor for x^3*/
    IMPFP     TV_PWR_2;         /* Multiplication Factor for x^2*/
    IMPFP     TV_PWR_1;         /* Multiplication Factor for x^1*/
    IMPFP     TV_C;              /* Constant addition*/
} UThermo, *UThermo_ptr;

```



```

/* Channel Post Linearisation equations*/
typedef struct
{
    IMPFP    PL_PWR_5;           /* Multiplication Factor for x^5*/
    IMPFP    PL_PWR_4;           /* Multiplication Factor for x^4*/
    IMPFP    PL_PWR_3;           /* Multiplication Factor for x^3*/
    IMPFP    PL_PWR_2;           /* Multiplication Factor for x^2*/
    IMPFP    PL_PWR_1;           /* Multiplication Factor for x^1*/
    IMPFP    PL_C;               /* Constant addition*/
}PL_eqn, *PL_eqn_ptr;

typedef struct
{
    UThermo  TCs[2];             /* User Thermocouples*/
    PL_eqn   Lins[2];            /* Post Linearisation equations*/
}DB4, *DB4_PTR;

/***** Typedefs for DATABASE 5,(182 Bytes) 6 & 7 (Both 180 Bytes) *****/

typedef struct                    /* Channel alarm structure*/
{
    IMPFP    HIGH;               /* Channel High limit*/
    IMPFP    HI_HYSTER;          /* Hysteresis value*/
    IMPFP    HI_COMPARE;        /* Current compare limit*/
    IMPFP    LOW;                /* Channel Low limit*/
    IMPFP    LO_HYSTER;          /* Hysteresis value*/
    IMPFP    LO_COMPARE;        /* Current compare limit*/
    BOOL     IN_HIGH;            /* IN_HIGH_ALARM*/
    BOOL     IN_LOW;             /* IN_LOW_ALARM*/
    BOOL     CH19_HI_ALARM;      /* True if HI is in CH 19 alarm group*/
    BOOL     CH20_HI_ALARM;      /* True if HI is in CH 20 alarm group*/
    BOOL     CH19_LO_ALARM;      /* True if LO is in CH 19 alarm group*/
    BOOL     CH20_LO_ALARM;      /* True if LO is in CH 20 alarm group*/
}CA, *CA_PTR;

typedef struct
{
    BYTE     CH19_GO_STATE;      /* CA_DISABLED, CA_ASSERT or
                                   CA DISSASERT*/
    BYTE     CH20_GO_STATE;
    CA       Alarms[6];
}DB5, *DB5_PTR;

typedef struct
{
    CA       Alarms[6];
}DB6_7, *DB6_7_PTR;

```

# 3595 4B PC-to-SNET Interface

User Manual

35952232

February 1999



## Mobrey Measurement

158 Edinburgh Avenue,  
Slough, Berks, SL1 4UE, UK  
T +44 (0) 1753 756600  
F +44 (0) 1753 823589  
mobrey.sales@EmersonProcess.com  
www.mobrey.com

## Mobrey Inc

19408 Park Row, Suite 320,  
Houston, TX 77084 USA  
T +281 398 7890  
F +281 398 7891  
mobrey.sales@EmersonProcess.com  
www.mobrey.com

Mobrey SA-NV	Belgium	tel: 02/465 3879
Mobrey GmbH	Deutschland	tel: 0211/99 808-0
Mobrey SA	France	tel: 01 30 17 40 80
Mobrey sp z o o	Polska	tel: 022 871 7865
Mobrey AB	Sverige	tel: 08-725 01 00

